

University of Business and Technology in Kosovo

UBT Knowledge Center

Theses and Dissertations

Student Work

Spring 5-2010

Marketing Concept and Its Application In Kosova's Enterprises

Halil Krasniqi

Follow this and additional works at: <https://knowledgecenter.ubt-uni.net/etd>



Part of the [Business Commons](#)

UNIVERSITY FOR BUSINESS AND TECHNOLOGY



MASTER THESIS

Dipl. Ing. HALIL KRASNIQI

Prishtina, 2010



MASTER THESIS

Marketing Concept and Its Application In Kosova's Enterprises

prepared for the Degree „Master of Science in International Engineering Management – MSc.IEM”

under the supervision
of

1st supervisor

Edmond HAJRIZI, Prof. Dr., University for Business and Technology – Kosova

2nd supervisor

Peter KOPACEK, Prof. Dr.Dr.h.c.m., Vienna University of Technology - Austria

submitted to

University for Business and Technology - UBT
and

Institute of Handling Devices and Robotics, Vienna University of Technology – IHRT/VUT

by

Dipl. Ing. **Halil Krasniqi**

Enrolment Number - IEME: **20030012**

Enrolment Number - VUT: **0327765**

Prishtina – Kosova

Prishtina, May 2010

TABLE OF CONTENTS:

MASTER THESIS	2
MARKETING CONCEPT AND ITS APPLICATION IN KOSOVA'S ENTERPRISES	2
UNIVERSITY FOR BUSINESS AND TECHNOLOGY - UBT	2
DIPL. ING. HALIL KRASNIQI	2
1 INTRODUCTION	9
1.1 WHAT IS MARKETING AND MARKETING CONCEPT	9
1.1.1 SELLING ORIENTATION	11
1.1.2 PRODUCTION ORIENTATION	12
1.1.3 PRODUCT ORIENTATION	12
2 STATE OF THE ART	14
2.1 THE MARKETING SYSTEM	14
2.2 MARKETING MANAGEMENT	18
2.2.1 THE FUNCTIONS OF MARKETING MANAGEMENT	18
2.3 MARKETING MIX	20
2.4 MARKET SEGMENTATION	24
2.4.1 WHAT IS THE MARKET?	24
2.4.2 MARKET SEGMENTATION DEFINITIONS	24
2.4.3 PATTERNS OF MARKET SEGMENTATION	27
2.4.4 MARKET SEGMENTATION PRECEDURE	27
2.4.5 SEGMENTING CONSUMER AND BUSINESS MARKETS	28
2.5 PRODUCT POLICY	35
2.5.1 PRODUCT DEFINITIONS	35
2.5.2 PRODUCT MIX	37
2.5.3 THE PRODUCT LIFE CYCLE	37
2.5.4 INVENTION, RESEARCH AND CREATIVITY	42
2.5.5 INNOVATION	42
2.5.6 BRANDS AND BRANDING	43
2.5.7 PACKAGING AND LABELING	46
2.6 PRICING STRATEGY	49
2.6.1 PRICE DEFINITIONS	49
2.6.2 SETTING THE PRICE	49
2.6.3 ADAPTING PRICES	53
2.6.4 PRICE CHANGE AND CUSTOMER ATTITUDE	54
2.7 DISTRIBUTION CHANNELS	57
2.7.1 INTRODUCTION	57
2.7.2 DISTRIBUTION CHANNEL ROLE	57

2.7.3	TYPES OF INTERMEDIARIES AND SELLING METHODS	60
2.7.4	USING MULTIPLE CHANNELS OF DISTRIBUTION	62
2.8	PROMOTION POLICY	64
2.8.1	PROMOTION DEFINITIONS	64
2.8.2	MARKETING COMMUNICATION AND COMMUNICATION THEORY	64
2.8.3	DEVELOPING EFFECTIVE MARKETING COMMUNICATION	65
2.8.4	ADVERTISEMENT	69
2.8.5	PERSONAL SELLING	74
2.8.6	PUBLIC RELATIONS	77
2.8.7	SALES PROMOTION	77
2.8.8	DIRECT MARKETING DEFINITION	79
2.8.9	HOW TO ESTABLISH A CUSTOMER CARE CULTURE	82
3	PROBLEM RESOLUTION	86
3.1	PROBLEM DEFINITION	86
3.1.1	IDENTIFY THE OBJECTIVES	86
3.1.2	COLLECTED DATA	86
3.2	PROPOSALS	93
4	SUMMARY AND FUTURE WORKS	99
4.1	FUTURE WORK	99
5	LITERATURE	100
6	APPENDIX	101

List of Figures

Figure 1.1 The marketing concept.....	10
Figure 2.1 A simple marketing system.....	14
Figure 2.2 Interaction between different levels in the marketing system	16
Figure 2.3 Technology and the system.....	17
Figure 2.4 The marketing mix tools	20
Figure 2.5 Building the marketing mix. ^a As decisions are made of information is gathered it may prove necessary to go back a step to rethink the ideas leading up to that point. ^b Borden, N.H. “The Concept of Marketing Mix”. ^c Kotler, P. “Marketing Decision – Making”.....	21
Figure 2.6 Market segmentation approach.....	26
Figure 2.7 The stages of marketing mix strategy	26
Figure 2.8 Basic Markets – Preference Patterns	27
Figure 2.9 Components of the Market Offering.....	35
Figure 2.10 Total product.....	36
Figure 2.11 Product life cycle	38
Figure 2.12 Exploiting the product life style.....	41
Figure 2.13 The new product development process.....	42
Figure 2.14 An Overview of Branding Decisions.....	45
Figure 2.15 New product packaging decisions	47
Figure 2.16 Pricing Strategies Matrix	50
Figure 2.17 Setting Pricing Policy	50
Figure 2.18 The three Cs model for price setting.....	52
Figure 2.19 How a distributor effects economy of effort.....	59
Figure 2.20 Consumer and Industrial Marketing Channels	59
Figure 2.21 The communication process model	64
Figure 2.22 Response Hierarchy Models	67
Figure 2.23 Cost effectiveness of different promotional tools at different buyer-readiness stages	69
Figure 2.24 The five Ms of Advertising.....	70
Figure 2.25 Main advertising media	72
Figure 2.26 Major steps in effective selling.....	76
Figure 3.1 The new networks.....	93
Figure 3.2 What does marketing actually do?.....	97

List of Tables

Table 2-1 Summary of marketing mix decisions	23
Table 2-2 Major Segmentation Variables for Consumer Market.....	32
Table 2-3 Major segmentation variables for business markets	33
Table 2-4 Product life cycle stages	39
Table 2-5 Some products and their PLC stages	39
Table 2-6 Levels of Brand Meaning	44
Table 2-7 Brand name strategies	46
Table 2-8 Price discounts and allowances.....	54
Table 2-9 Channel of distribution objectives	58
Table 2-10 Common communication platforms	66
Table 2-11 Mass marketing versus One-to-one marketing	81
Table 2-12 Calculation of worth of a customer.....	83
Table 3-1 Common prices for advertising spots in RTK	92
Table 3-2 Prices of RTK during special programs of RTK	92
Table 3-3 Prices of placing products into programs of RTK	92
Table 6-1 Sample of a survey questioner	101

PROBLEM FORMULATION

Although ten years spent that the war in Kosova is over, the rule of law is not taking place in all its capacities still. It is well known already that by government of Republic of Kosova, the newest country of the world is oriented toward so-called Free-Market Economy economic system. Four main pillars of Free-Market Economy system are:

- Private property domination
- Profit as force that push things going forward
- The right of choosing free business activity
- Competition

Whereas, the role of state in this Free-Market Economy is: to ensure economic stability, social justice and system efficiency.

The orientation toward Free-Market Economy has enabled creation of too many new companies in Kosova, mainly dealing with small businesses. But, having in mind the presence of state as a next complementary factor that enables creation, existing and development of Free-Market Economy system, then the lack of rule of law in full capacities here in Kosova creates a self paradox for the possibilities of existing and development of these companies specifically and of Kosova economic development generally. Furthermore, this paradox pushed me that within existing possibilities in our social-economic circumstances to make a comparison between marketing as a concept and its application in enterprises of Kosova, and to analyze functionality or non functionality of these companies due to this issue.

However, since the end of the Kosovo war, some economic growth has been noticed, democratic institution and market economies slowly are being created and strengthened, regional trade links with some neighbor states are being created, and private investments are launched slowly.

Specifically, aspiration of this thesis is that, how much are these companies aware of the new modern concept of marketing. If they somehow are, then how much apply and spent money to fulfill marketing concepts needs. Eventually, by using world-wide sources of literature and different experiences how much these companies apply and need to apply the elements and possibilities that marketing concept offers.

Concerning marketing system and environment it was chosen a very detailed analysis of business environments in Kosova. That of Dale Pfeiffer the head of USA office in Kosova was chosen. Poor transportation structure, legal economical system, lack of electrical energy, foreign trade relations, private investments and as a last environmental factor here the political status uncertainty were mentioned.

In the second chapter, point 2.2 the role and tasks of marketing management will be prescribed including planning, organizing, motivating and controlling.

The marketing mix and market segmentation are going to be described in points 2.3 and 2.4 of the second chapter respectively. Market segmentation definitions, patterns of market segmentation, market segmentation procedures will be explained.

Since marketing concept comprises four main components, the main focus of entire job has been oriented on explaining them. Product, price, distribution channels and promotion policies will be analyzed in second chapter, too. Since the number of manufactories in Kosova

is very small, some examples of treatment by them of their products were given. After introduction and detailed description of each element, examples of using these by companies in Kosova will be given. Some examples of advertisements prices have been provided as well.

In the third chapter, it was tried to give some explanations of collected data and some proposals and recommendations mainly regarding customer care and its staff role. Even if this is the last chapter, the culture of customer care staff regarding its importance should be ranged somewhere in the beginning of the marketing system in its own.

As e method of collecting information will be used some researches made by some researchers whose collected data have been made public. Some other data will be collected and investigates made by myself during daily life. I'll try to talk with people dealing with this subject and trying to analyze their behavior and knowledge of marketing elements. So, by analyzing the collected data, in the same time it will be given proposals for the possible solutions taken from the best world literature and people experiences.

In all chapters the theoretical bases and concepts of discussed topic will be given first. A detailed description of concerned topic will be given, and some well known authors will be cited. Next, these theoretical concepts are going to be compared with real situation and circumstances of companies in Kosova. And finally, based on these analyses the appropriate estimations and proposals are trying to be given.

1 INTRODUCTION

1.1 WHAT IS MARKETING AND MARKETING CONCEPT

Based on the complexity of modern concept of marketing, it is hard to define it in one expression □ what marketing is. However, there are a lot of expressions coming from various authors concerning this concept. Therefore, we will provide here citations from some of them, which describe marketing in more general terms, as it is important to know and understand more than one reference to it. One thing is clear that marketing links two basic functions in the community, namely those of **production** and **consumption**. **Marketing is an activity which is directed at satisfying the needs and wants of customers through exchange processes which occur in the market**¹. An exchange process means the transaction which occurs between seller and buyer, in which the buyer purchase a product/service and pays to the supplier an agreed price for his ware. It should be clear that the market is not made up of just the actual buyers, but of all actual and potential buyers of these products or services. That means it is made up of people. Let's have a look at what other authors say about marketing:

- **Marketing is the management process responsible for identifying, anticipating and satisfying customer requirements profitably**².
- **Marketing is the process by which a product or service is first originated and is then priced, promoted, and distributed to consumers**³
- **The marketing concept stresses the belief that an organization should aim all its efforts at anticipating and satisfying its customers at a profit**⁴
- **A social and managerial process by which individuals and groups obtain what they need and want through creating and exchanging products and value with others**⁵.
- **Consisting of individual and organizational activities that facilitate and expedite satisfying exchange relationships in a dynamic environment through the creation, distribution, promotion, and pricing of goods, services, and ideas**⁶.

What is the “Marketing Concept” indeed? It can be defined as⁷:

The most important managerial task within the organization is that of understanding the needs and wants of customers in the market, and of adapting the operations of the organization to deliver the right goods and services more effectively and efficiently than its competitors.

From above definition it seems that two are the main company's management tasks:

1. To observe the market needs – means to observe the market changes. So, should attend and investigate the nature of these market changes. Market needs and fulfilling effectively and profitable way of these needs should remain the driving force during the decisions of all company's managers, not just marketing managers.
2. Market-oriented operations management – all company's activities should be oriented in a manner to achieve the marketing objectives and in the same time in the competitive and profitable manner.

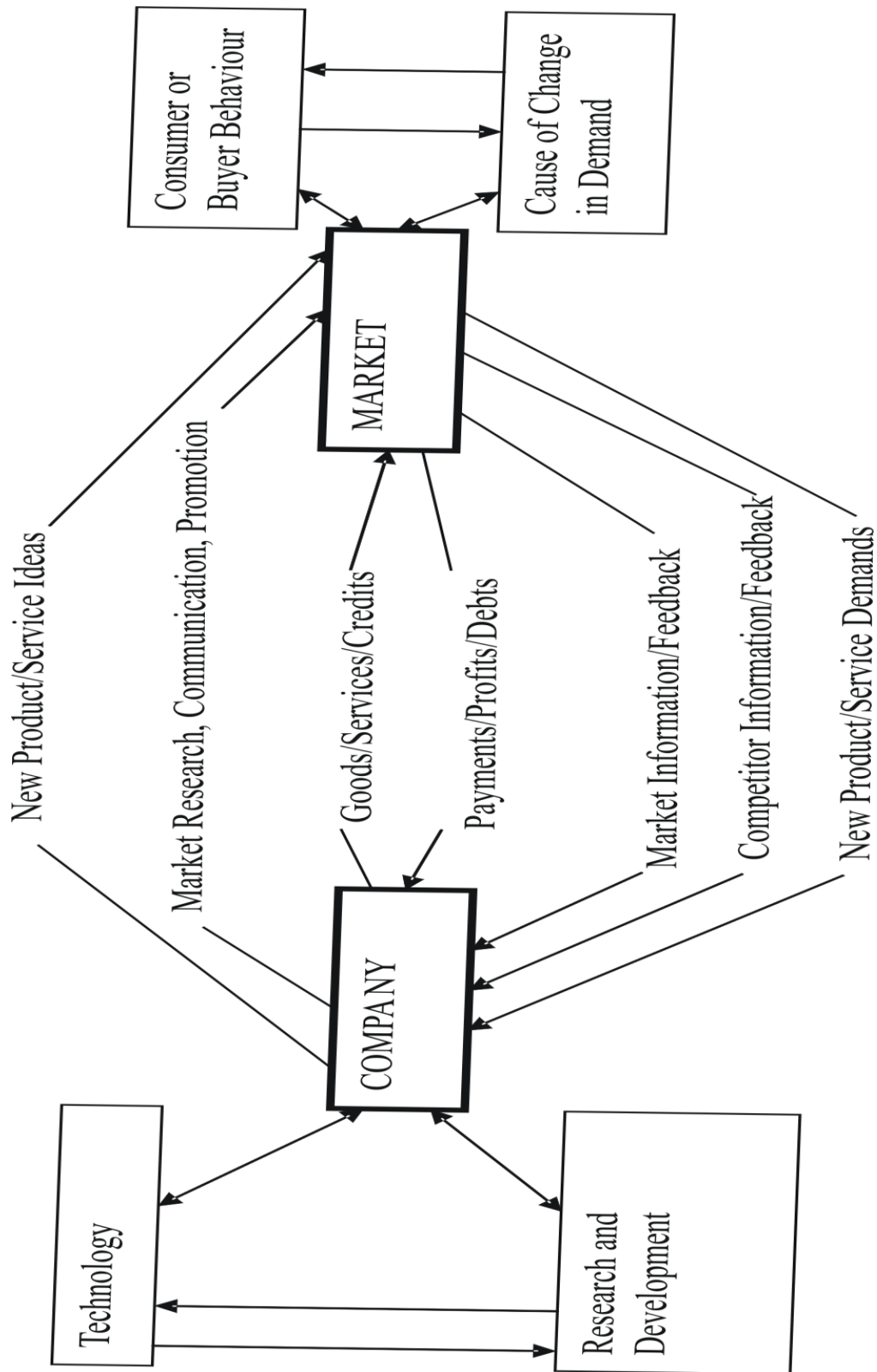

Figure 1.1 The marketing concept⁸

This new marketing concept is a philosophy. It makes the customer, and the satisfaction of his or her needs, the focal point of all business activities. It is driven by senior managers,

passionate about delighting their customers. Below have been some definitions about marketing concepts⁹.

First one - Peter Drucker says: **“Marketing is not only much broader than selling, it is not a specialized activity at all it encompasses the entire business. It is the whole business seen from the point of view of the final result, that is, from the customer’s point of view. Concern and responsibility for marketing must therefore permeate all areas of the enterprise”**.

Another author, Simon Barwell says: **“This customer focused philosophy is known as the ‘marketing concept’. The marketing concept is a philosophy, not a system of marketing or an organizational structure. It is founded on the belief that profitable sales and satisfactory returns on investment can only be achieved by identifying, anticipating and satisfying customer needs and desires”**.

While Cohen is expressed like this: **“The achievement of corporate goals through meeting and exceeding customer needs better than the competition. Implementation of the marketing concept requires attention to three basic elements of the marketing concept. These are: Customer orientation; an organization to implement a customer orientation; Long-range customer and societal welfare”**. The marketing concept is illustrated in Figure 1.1. Now have been introduced some definitions of marketing and the marketing concept and some important elements should remember, contained as follows:

- Marketing focuses on the satisfaction of customer needs, wants and requirements;
- The philosophy of marketing needs to be owned by everyone from within the organization;
- Future needs have to be identified and anticipated;
- There is normally a focus upon profitability, especially in the corporate sector. However, as public sector organizations and not-for-profit organizations adopt the concept of marketing, this need not always be the case.
- More recent definitions recognize the influence of marketing upon society.

Implications concerning believing in the marketing concept become clearer when it comes to examination of alternatives: There are three main alternatives to adopting other than marketing orientation. These are: Selling orientation, Production orientation and Product orientation. These are described briefly below, trying to justify their application in some markets.

1.1.1 SELLING ORIENTATION

The selling orientation phase ran from the mid 1950's to the early 1970's, and is therefore followed the production orientation phase but preceded the marketing orientation period. During WWII world industry geared up for accelerated wartime production¹⁰. The best explanation found concerning this alternative of selling was one which says: “after the war was over, this stimulated industrial machine turned to product for consumption. By the mid 50's supply was starting to out-pace demand in many industries. Businesses had to concentrate on ways of selling their products. Numerous sales techniques such as closing, probing, and qualifying were all developed during this period and the sales department had an exalted position in a company's organizational structure. Other promotional techniques like advertising, and sales promotions had started to be taken seriously. Packaging and labeling were used more for promotional purposes than protective purposes. Pricing was usually based on comparisons with competitors (called competitor indexing)”¹¹.

Currently some businesses see as their main problem selling more of the product or services which they already have available. They may therefore be expected to make full use of selling, pricing, promotion and distribution skills (just like a marketing-orientated business). The difference is that a sale-orientated business pays little attention to customer needs and wants, and does not try particularly hard to create suitable products or services¹². In selling orientation concept the sale finishes after the act of selling. In contrast, in marketing concept sale continue also after the act of selling (with product guarantees, product maintenance by seller, etc.). There is a need for both selling and marketing approaches at different situations. One approach is not always right and the other always wrong– as it depends upon the particular situation. The objective of such a concept is the effort to sell a product that a business has produced as quickly as possible aiming at fulfilling sales volume objectives. When viewed through the marketing concept lens, however, businesses must first and foremost fulfill consumers' wishes and needs. The belief is that when those wants and needs are fulfilled, a profit will be made¹³. The selling orientation, is not focused consumer demands, rather it tries to make consumer demand match the products it has produced. Regarding the difference between the marketing and sales concepts a marketing expert Michael Richter said¹⁴:” **Selling is the direct interaction between the seller and the buyer, whilst marketing is the interaction between the company and the markets - including, of course, the selling action. Finally, marketing has to be the 'frame' of the company. 'Frame' means that every action of the company has in the end to be directed towards its markets/clients - from developing 'marketable' products to the 'selling action'.**”

1.1.2 PRODUCTION ORIENTATION

A production-orientated business is said to be mainly concerned with making as many units as possible¹⁵. Meeting market demand is seen as supply problem. Thus, customers will have to accept whatever goods or services a supplier chooses to make available to them. So, by concentrating on producing maximum volumes, such a business aims at maximizing profitability by exploiting economies of scale. To a production orientated business, the needs of customers are secondary compared to the need to increase output. Such an approach is probably most effective when a business operates in very high growth markets or where the potential for economies of scale is significant.

1.1.3 PRODUCT ORIENTATION

This alternative is slightly different from a production orientation. “Consider a business that is “obsessed” with its own products – perhaps even arrogant about how good they are. Their products may start out as fully up-to-date and technical leaders”¹⁶. A firm that is product oriented hopes that the quality and features of its product will be the key to the successful marketing and selling of the product. However, by failing to consider changing technological developments or subtle changes in consumer tastes, a product-orientated business may find that its products start to lose ground to competitors. Such policies may work as in a case of some Japanese electronic products. Often they fail, as in a case of spectacular but commercially unsuccessful Concorde civil airplane.

Reference:

- ¹ Morden A.R., Elements of Marketing, 1993
- ² UK Chartered Institute of Marketing , In: Morden A.R., Elements of Marketing, 1993
- ³ Brett Robbs, In: Microsoft Encarta Encyclopedia Deluxe 2004
- ⁴ Perreault, McCarthy, Parkinson and Stewart, Basic Marketing, 1999
- ⁵ Kotler P., Principles of Marketing, 1995
- ⁶ Rexha N. and Reshidi,N., Basics of Marketing , 2002
- ⁷ Morden A.R., Elements of Marketing, 1993
- ⁸ Morden A.R., Elements of Marketing, 1993
- ⁹ From source: www.marketingteacher.com
- ¹⁰ Adopted from: www.absoluteastronomy.com
- ¹¹ <http://www.nationmaster.com/encyclopedia/Sales-orientation>
- ¹² Adopted from: <http://tutor2u.net>
- ¹³ Adopted from: <http://www.peacemotivate.com>
- ¹⁴ Adopted from: <http://tutor2u.net>
- ¹⁵ Adopted from: www.absoluteastronomy.com
- ¹⁶ Adopted from: <http://tutor2u.net>

2 STATE OF THE ART

2.1 THE MARKETING SYSTEM

Before discussing the marketing system, first let's explain what system itself is. A system is an assemblage or combination of elements or parts forming a complex or unitary whole¹. Systems are composed of **components, attributes, and relationships**. **Components** are the operating parts of a system consisting of input, process and output. They are designed to achieve certain goals, either their own or the system's goals. **Attributes** are properties or discernible manifestations of the components of the system. **Relationships** are links between components and attributes. Everything that remains outside the boundaries of the system is considered to be the system **environment**.

Marketing system and its environment are two very important parts which the company and its competitors, suppliers and customers should understand to have an effective marketing. That's why managers must appreciate²:

- The business environment: such things are the conditions, primarily economic, political, cultural and technological, under which the marketing system(s) exists or is developed.
- The marketing system: the set of significant institutions and flows that connects an organization to its markets. An author, Rexha.N, says³: “based on the general system theory product, price, distribution and promotion as synchronized business activities and interacting to each other make up the marketing system”.

Bellow in Figure 2.1, it's pointed out the very simple example of marketing system, illustrated with the traditional trading farmer.

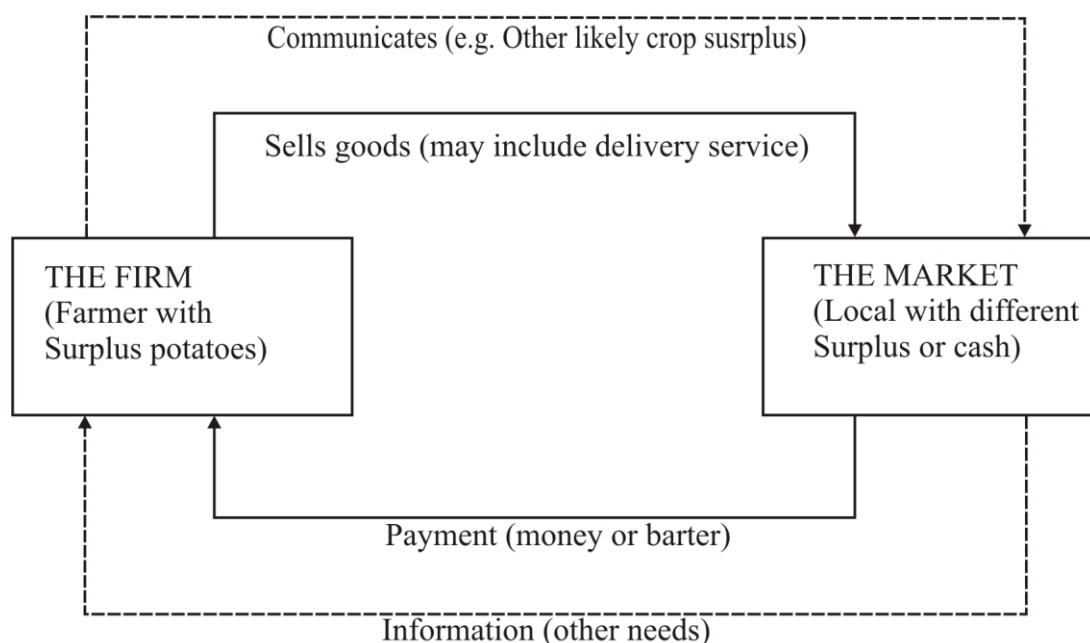

Figure 2.1 A simple marketing system⁴

From example above, the firm, market and all their interrelated links make up this simple marketing system. Based on the system's definition, it is obvious that in a traditional trading

farmer's case, as a system's component can be considered the sale of goods in the market. On the other side sale itself serves the marketing system, that is firm and market as consisting parts of marketing system.

On the other hand the business environments are always changing. There are three key factors on the marketing system environment, namely the Micro-environment, the Macro-environment and internal environment⁵.

The micro-environment - This environment influences the organization directly. It includes suppliers that deal directly or indirectly, consumers and customers, and other local stakeholders. Micro tends to suggest small, but this can be misleading. In this context, micro describes the relationship between firms and the driving forces that control this relationship. It is a more local relationship, and the firm may exercise a degree of influence.

The macro-environment - This includes all factors that can influence an organization, but that are out of their direct control. Such factors are economic, political, cultural and technological. A company does not generally influence any laws (although it is accepted that they could lobby or be part of a trade organization). It is continuously changing, and the company needs to be flexible to adapt. There may be aggressive competition and rivalry in a market. Globalization means that there is always the threat of substitute products and new entrants. The wider environment is also ever changing, and the marketer needs to compensate for changes in culture, politics, economics and technology.

The internal environment - all factors that are internal to the organization are known as the 'internal environment'. They are generally audited by applying the 'Five Ms' which are Men, Money, Machinery, Materials and Markets. The internal environment is as important for managing change as the external.

The ability to manage change effectively is one of the key determinants of company's success. Kotler suggests that the company system and environment can be viewed in terms of three levels: the general environment, different publics and the marketing system⁶. These are in a state of constant interaction, not only within each level but across different levels. Figure 2.2 illustrates how macro-environment forces— economic, political, cultural and technological shape the marketing system and the commercial relationships within it.

Taking into account the importance that macro-environment forces have into a marketing system, further it will be discussed briefly about them.

Economic policies - Although the supply and demand issues are bases for a free market economy, many other aspects of economic environment help to create the conditions under which companies operate.

Technology - There are already well known technological developments that took place in recent years. These technological changes had a direct impact on the marketing system, from manufacturers (there is a very small number of them in Kosova!), intermediaries and customers. Companies must keep pace with all these changes, because these technological developments in turn have changed customer needs. Therefore, in order to be closer to customer needs, a company should necessarily observe these changes⁷.

Political factors - The political environment as a factor has a huge influence on regulation of businesses and these regulations have a direct impact on the marketing system.

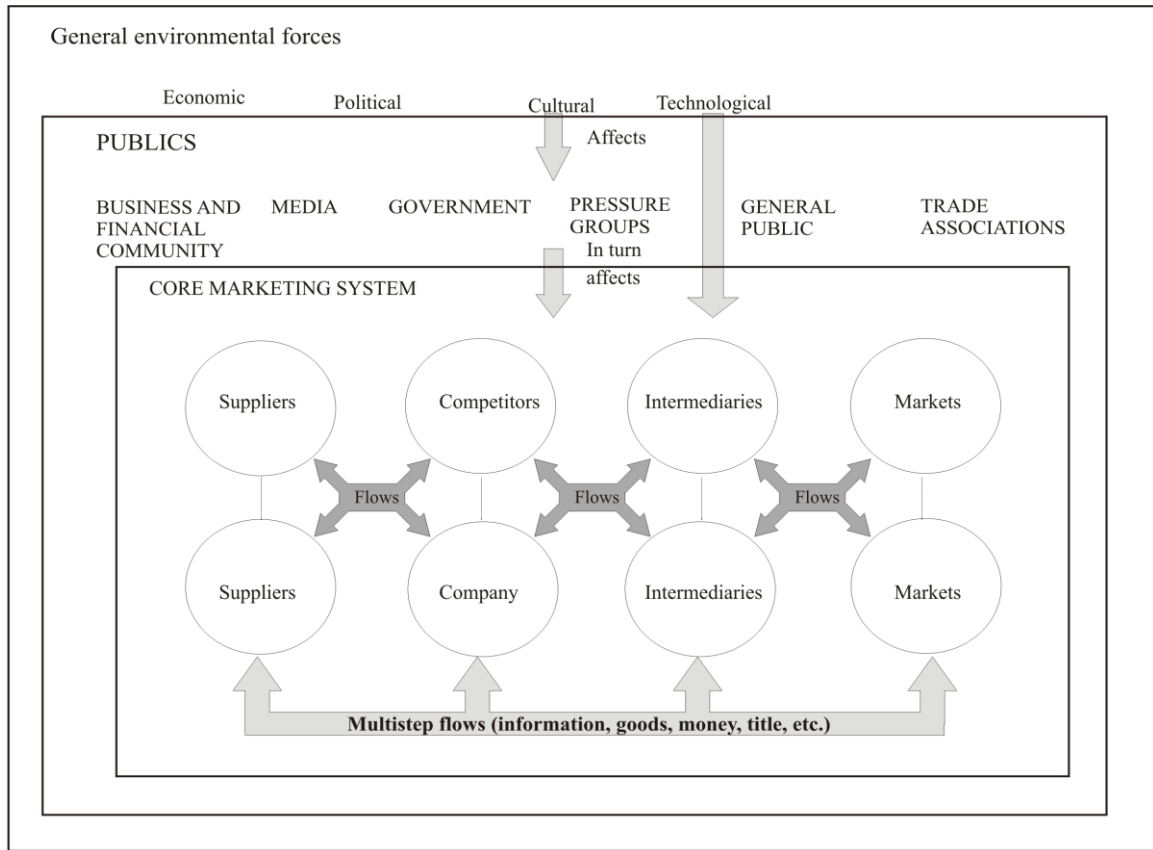

➔ Flows: information, goods, money, title, service

Figure 2.2 Interaction between different levels in the marketing system⁸

Although technological progress is a result of world-wide research, the small and medium companies cannot have an impact on them, or cannot change the direction of their developments. So it remains to them to anticipate the technical and technological developments, in order for them to be oriented in the same direction as these developments. However, small and medium size companies should attempt to make their best in exploiting advantages provided by technological development. In Figure 2.3 below it seems obviously that new technologies have an impact throughout the marketing system in shaping availability, cost and ultimate consumption of goods. Some new technologies affects marketers directly, notably videotext for information transmission, minicomputers and microcomputers for handling problems and analysis, beside satellite, video film and cable television.

Culture - Culture plays an important role in the marketing system, especially in the market itself. Because culture determines many of human's patterns behavior. This in turn, impact on the potential purchase power in the market. Let's assume that you have decided to sell alcohol drinks somewhere in any Arabic Muslim country. It's known that Islamic societies are often characterized by an absence of alcoholic drinks. So this initiative will fail for sure. Culture can be defined as distinctive patterns of behavior which result from basic beliefs and traditions.

The different public - Although it is already clear that marketing system is influenced by macro – environment factors, much of those factors are interpreted and judged by different specialized common interests groups.

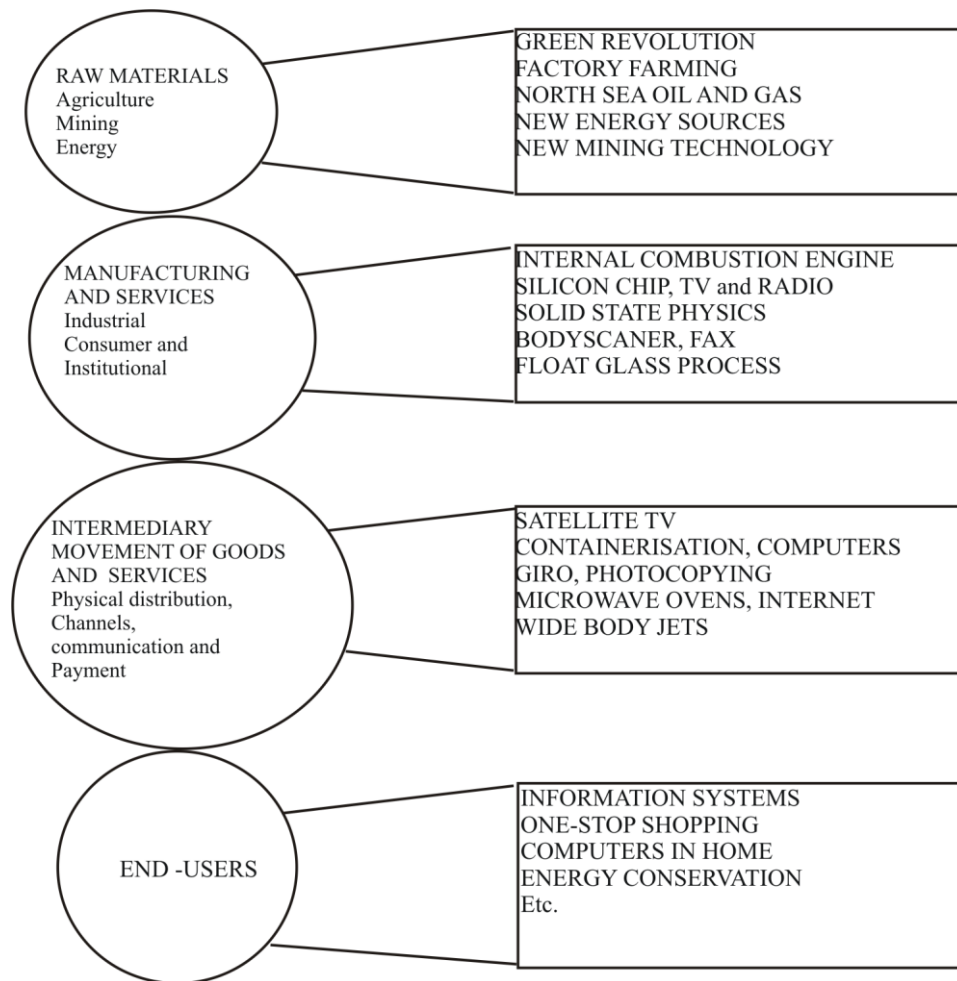

Figure 2.3 Technology and the system⁹

The media - can have a direct impact on business confidence besides influencing specific firms and markets, especially the mass national and international can have a substantial effect on markets.

Reference:

- ¹ Blanchard B., and Fabrycky W., Systems Engineering and Analysis, 1997
- ² Cannon T., Basic Marketing, 1996
- ³ Rexha N. and Reshidi N Basics of Marketing, 2002
- ⁴ Cannon T., Basic Marketing, 1996
- ⁵ Adapted from www.marketingteacher.com
- ⁶ Kotler P., Framework for Marketing Management, 2001
- ⁷ Cannon T., Basic Marketing, 1996
- ⁸ Kotler P., Framework for Marketing Management, 2001
- ⁹ Cannon T., Basic Marketing, 1996

2.2 MARKETING MANAGEMENT

So far it was tried to explain the contents and importance of marketing. Let's make a simple question: who is responsible for putting into practice this concept? – Marketing management, for sure. Marketing management has to do this by¹:

- Making sure that all company's activities (including production, financial activities, etc) identify, anticipate and satisfy the customer needs, requirements and wishes in an effective or profitable manner. Marketing is not an activity that belongs exclusively to one person who has the marketing described to his or her job description. Rather it is an activity in which must be included all employees in the company. Concerning this topic let's have a look to some simple examples: a washing machine producer can have marketing department, but the service engineer of sold washing machines through his day-to-day contacts with customers for sure will have a great impact on them. So if he has some marketing background than he will reinforce relations with company's customers. Otherwise the opposite will happen and these so far good relations will be weakened. Another example is bank, which also can have its marketing department, but any manager within a bank is in a direct contact with the clients. Means, any manager should know something about marketing department objectives, thus company's objectives.
- Making sure that all company's activities operate in a market-oriented manner, relative to the company's financial objectives and obligations. Commitment of all employees in company to the marketing concept is important as much as the company's promotional activity itself.

It will do this by incorporating the marketing concept into the all management functions for which it is responsible. So, marketing management is a process of planning, organizing, implementing and controlling marketing activities to facilitate and expedite exchanges effectively and efficiently.

2.2.1 THE FUNCTIONS OF MARKETING MANAGEMENT

Usually are defined four main management functions. According to Morden, a management in an organization is responsible for²:

- Planning
- Organizing
- Motivating, guiding, directing or leading
- Controlling

Planning - marketing management here has three main tasks. First one is that it must contribute to the whole company's business plan. In this issue marketing management should has a great role in the matters as: in what business should company be oriented, what kind of products or services it should offer, to which segments of market should be concentrated and on what and how investments the company should be oriented. The second task of marketing management in planning is to anticipate the market and the potential sales on that market for the annual operative and budgeted plan of company. And the third one is a detailed planning of sales and marketing activities on those sectors where it has a direct control. The timing of

these three tasks varies from several weeks or months to several years (in a case of planning, developing and launching a new product).

Organizing – about organizing the marketing management has three responsibilities. First one is to coordinate activities with other company's sectors, as with production sector, product distribution sector, financial sector, human resources, etc. All of this should be made on purpose to impact on these sectors be market oriented. Second responsibility of marketing management concerning organizing issue is to organize in such a manner that all sales and marketing activities, means activities on which it has a direct control, to be cost effective.

Motivating, guiding, directing or leading – two are the responsibilities of marketing management. First one has to do with motivating and guiding of other business units aiming to be deeply market oriented. This can be achieved by advising, convincing or making them clear the risk of deviating from market oriented strategy. Marketing management also should prepare a presentation skills and policy to make sure that its views are well represented during the decision making process in the company. Whereas the second responsibility has to do with staff that is direct included in implementing of marketing decisions and strategies. This staff should be specially motivated and guided, on purpose to fulfill the marketing department objectives.

Controlling - managers are responsible to monitor and to adjust company's activities on purpose to achieve company's objective. This is called control process. This is valid for marketing management too. Thus marketing management is responsible to control the fulfilling of marketing department's objectives. Among these objectives more important are: sales income, launching new product on the market, making of effective promotional activities, etc. Success or failing of other departments is depended from the success or failing of marketing department. Because marketing department should had to have the close relations with those departments.

Reference:

¹ Morden A.R., Elements of Marketing ,1993

² Morden A.R., Elements of Marketing ,1993

2.3 MARKETING MIX

In order for a business to sell its products and services as successfully as possible, it needs to look at what company's products are sold in detail to ensure they will be attractive and needed. Then needs to look at the price to ensure it is not too cheap or too expensive, means the right one. Next step is to see at where the company is best distributing its product, and finally, how you can create interest and awareness for products. All these elements need to be targeted at the right people at the right time. In order for a business to tackle this correctly, it needs to get the right type of mix (marketing mix), the mix should include four main elements: Product, Price, Place and Promotion, by examining each carefully and adapting them to customer's needs¹.

The term "marketing mix" became popularized after Neil H. Borden published in 1964 his article "The Concept of Marketing Mix". Borden began using the term in his teaching in the late 1940's after James Culliton had described the marketing manager as a "mixer of ingredients". The ingredients in Borden's marketing mix included product, planning, pricing, branding, distribution channels, personal selling, advertising, promotions, packaging, display, servicing, physical handling, and fact finding and analysis. Among other grouping of these mix elements, the most popular is McCarthy's the four P's²: product, price, promotion and place which are depicted bellow in Figure 2.4. Now let's have a look at some definition about the marketing mix:

- **The marketing mix is the set of controllable variables that the company uses to influence the buyers response³.**
- **The marketing mix can be defined as the combination of detailed strategies, tactics, operational policies, programs, techniques and activities to which resources may be allocated such that the company's marketing objectives are achieved⁴.**

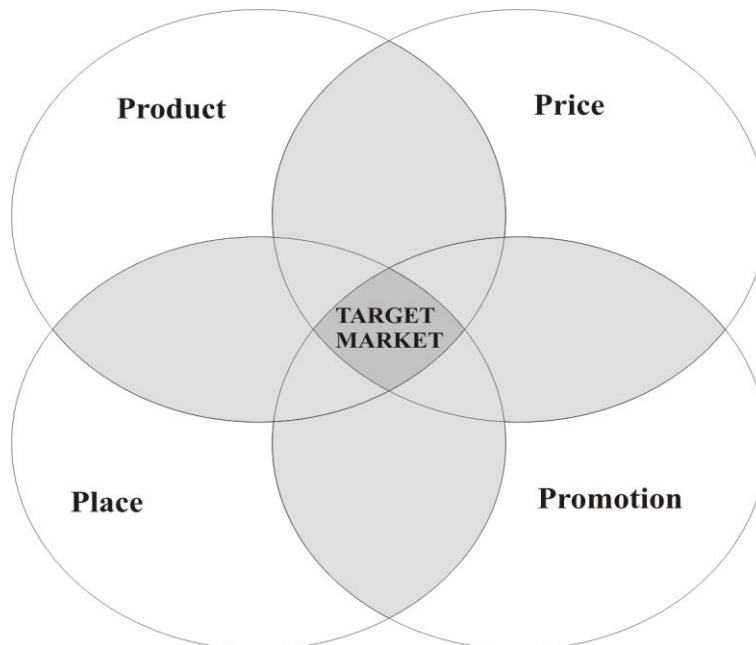

Figure 2.4 The marketing mix tools⁵

In practice it is not difficult to make decisions in each part of the mix separately. Also it might be not difficult to mix the parts which fit the internal requirements of a company. The state of the art is to mix elements in such a manner to fit between manageable resources and the needs of specific customers groups. This means that marketing mix depends on a clear vision of the customer group and target market and the resources of the firm. So a mix created without targeting or focusing on a market segment has no value. The four P's are designed to⁶:

- Create a combination meeting customer needs and wants
- Achieve competitive advantage
- Satisfy legal requirements

An author, Driver examined the importance of these and noted that⁷:

“The prevailing conception of marketing in terms of four P's, which largely excludes competitive and legal considerations, has tended to isolate marketing from a context which is a matter of practical and public importance”.

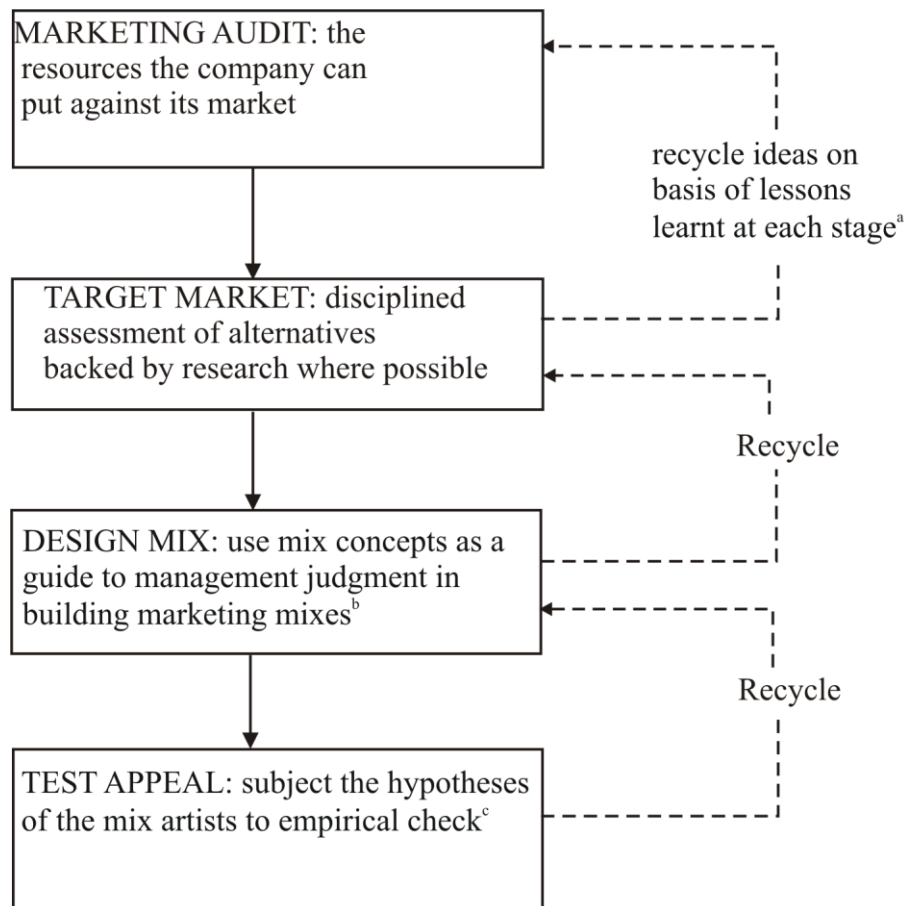

Figure 2.5 Building the marketing mix. ^aAs decisions are made of information is gathered it may prove necessary to go back a step to rethink the ideas leading up to that point. ^bBorden, N.H. “The Concept of Marketing Mix”. ^cKotler, P. “Marketing Decision – Making”.⁸

Borden⁹ suggests that designing the mix is a combination of arts and sciences, calling for a multi-step approach (Figure 2.5). In Figure 2.5 it is presented the possibility of designing the marketing- mix. As is seen, after every undertaken step it should review again the previous step. So during designing of company’s marketing mix it should be made the recycling of information and ideas from successor to predecessor step. Let’s start first from the first step

“Marketing Audit”, which allocate the resources of the company against its market. Then after assessment of alternatives backed by some researches again it should check back the “Marketing Audit” step and perhaps it needs to reallocate supplementary resources. Thus, the recycling of information and ideas is done step by step until the marketing mix is design and somewhat is tested by any further applied method.

One significant factor that should take into account after designing the optimum combination of elements is that this combination changes as the product passes through its life- cycle, as environmental forces change, as consuming and intermediary groups adapt, and as competition respond. The design of the initial mix will therefore need to be able to respond to new circumstances.

An author, A.R. Morden has mentioned that there is interdependence within each element and between each element of four elements of marketing mix¹⁰:

- The interdependence within each element is expressed among ingredients and component activities which make up each of the four marketing mix element. For instance, the larger the sales force, the less the need for heavy advertising expenditure. Similarly, the product which is marketed under a prestigious brand name may enjoy a much longer market life cycle than basically similar products which lack a strong brand. In consequence, product planning, and research and development activities may concentrate resources on the product and the brand, so further strengthening its position relative to the competition.
- The interdependence between each element is expressed on lots of examples that show the impact of an element to another one. For instance, the size of the sales force (**Promotion**) depends on the distribution channel (**Place**) to be used. The more intensive to be the distribution, the larger will be the sales force. Alternatively, the more the company wishes to rely on wholesalers, agents or trade distributors, the smaller will be the sales force but the more important becomes advertising to the final customer group. Another example is the brand image (**Product**), which must be reinforced by the pricing policy (**Price**) applied to the brand. Customers will expect to pay more for a reputable brand, but they will also expect the price charged to be consistent with their perceptions of the product’s appropriate usage context. Or, last example shown here is: the amount and style of advertising and sales promotion (**Promotion**) will influence the customer’s perceptions of the product, which in turn must influence on-going company product and brand development activities (**Product**).

The marketing management must take this interdependence into account, aiming to ensure the functioning of designed mix. The modification of one element of marketing mix can have repercussions within each element. Accordingly, a problem in one sector of marketing mix can be solved by an adjustment in another. For instance, a product may carry a high price which cannot easily be reduced, for instance because of research and development cost. Initially this product may be not competitive. But familiarizing the customers through promotional methods with product’s benefits and product’s features that competition do not offers, the product differentiation is perceived in a positive light by customer. Thus, this extra price will be viable. Furthermore, Morden says that: “**The skill of the marketing manager therefore lies in understanding how the four categories of the marketing mix interact and in being able to combine them in the most cost effective manner such that the company’s marketing objectives are satisfactorily achieved**”¹¹.

Table 2-1 Summary of marketing mix decisions¹²

PRODUCT	PRICE	PLACE	PROMOTION
Functionality	List price	Channel members	Advertising
Appearance	Discounts	Channel motivation	Personal selling
Quality	Allowances	Market coverage	Public relations
Packaging	Financing	Locations	Message
Brand	Leasing options	Logistics	Media
Warranty		Service levels	Budget
Service/support			

The Table 2-1 summarized the marketing mix decisions, including a list of some of the aspects of each of the 4Ps.

Reference:

¹ Adopted from: www.businessbureau-uk.co.uk

² Adopted from: www.netmba.com

³ Cannon T., Basic Marketing , 1996

⁴ Morden A.R., Elements of Marketing , 1993

⁵ Adopted from: www.quickmba.com

⁶ Cannon T., Basic Marketing , 1996

⁷ Adopted from: www.netmba.com

⁸ Cannon T., Basic Marketing , 1996

⁹ Borden N.M, In his article 'The Concept of the Marketing Mix', 1965

¹⁰ Morden A.R., Elements of Marketing, 1993

¹¹ Morden A.R., Elements of Marketing, 1993

¹² Adopted from: www.quickmba.com

2.4 MARKET SEGMENTATION

2.4.1 WHAT IS THE MARKET?

Before discussing the market segmentation process, one perhaps, first needs to have a look at some of the market definitions. **The market is the place where the sellers offer their products and buyers buy those offered products with an agreed price. During this trade off the proprietorship of the product is passed from the seller to the buyer.**

However, in modern times, mainly following invention of the electronic computer, markets are not always located in a physical space. Such virtual markets consist of communication paths where exchange in information is easy and deals may be struck. The international currency market is a notable example to support this.

Depending to whom the product may be destined, the market can be divided in the¹:

- Consumer market; and
- Business market

Consumer market consists from the buyers which consume their purchased products and do not use them for other purposes as making profit by resell them. All of us belong to this market by purchasing foods, clothes, etc.

On the other hand, the business market consists of all organizations that acquire goods and services used in the production of other products or services that are sold, rented, or supplied to other customers. The major industries making up the business market are agriculture, forestry, and fisheries; mining; manufacturing; construction; transportation; communication; public utilities; banking, finance, and insurance; distribution; and services. In general more money is involved and items are involved in business market than in consumer market. For example, let's consider the process of producing and selling drinks. The producers of raw material (special additives) must sell to dealers, who sell these materials to the drink producer, who sell drinks to wholesalers, who sell drinks to retailers, who finally sell them to consumers. Each party in the supply chain also has to buy many other goods and services, which means that every business seller is a business buyer, as well.

2.4.2 MARKET SEGMENTATION DEFINITIONS

Market segmentation means: **“the analysis of a particular market demands on the basis of its constituent part, so that sets of buyers can be differentiated”**². These sets of buyers should possess distinguishing characteristics, so that:

- They may be used as marketing targets against which products are positioned to meet segment customer needs; and
- A Marketing Mix appropriate to a particular segment may be selected;

Authors Clifford and Cavanagh have expressed the significance of market segmentation like this³: “Companies with high growth of business have succeed only by finding out and fulfilling needs of certain consumers by certain products and services, but not of all consumers and not by all products and services. This strategy the professors of universities call market segmentation, while successful businessmen call good sense”.

Since every company cannot serve successfully the needs and desires of every customer in the market, it must break down the total market demand into its component parts. These parts are called **market segments**. According to Kotler, market segments are very useful for marketing purposes and operational planning purposes too. “**A market segment consists of a large identifiable group within a market, with similar wants, purchasing power, geographical location, buying attitudes, or buying habits**”⁴. For example, an automaker may identify four broad segments in the car market: buyers who are primarily seeking basic segmentation, those who are seeking high performance, those seeking luxury, and those seeking safety. Segment members are similar but not identical from the viewpoint of their needs, preferences, and behavior. Thus Anderson and Narus⁵ urge marketers to present **flexible market offerings** instead of one standard offering to all members of segment. A flexible market offering consists of products and services that all segment’s member value, plus additional options that some segment’s members value, for an additional charge of course. There are some airlines companies that offer for all economy passengers a seat, food, and soft drinks, but they charge extra for alcoholic drinks and earphones.

But according to Kotler⁶, the companies did not always attend the segmentation strategy regarding the market. Their attitudes regarding the market have traversed through three stages:

1. “Mass market – in certain cases the company has chosen the entire market as its target market. For these types of enterprises that prepare only one marketing mix combination is thought to adopt a mass market approach. Starting point of this approach is that all customers in mass market have the same needs and wishes. Thus these needs and wishes can be successfully fulfilled by only one product mix combination (by standard product, by same prices, by one manner of distribution channels and one combination of promotional methods). According to this approach Coca – Cola has run according to this approach for a time, producing only one kind of Coke hoping that it would fulfill the need of every customer. The reasoning of this approach is based on assumption that mass market enables production and finalizing of products with lower costs per unit, enables more favorable prices and crates a bigger potential market. But in practice the companies are being faced everyday by the fact that in consumer and business market two customers can not be completely the same. So it is noticed that in the market is being merged the opposite tendency of that of mass market. The mass market approach can be eventually exploited in two more cases. First case is that where the distinctions among customers’ needs for certain products are very small. This occurs rarely. The second case is that when the company wants to keep only one marketing mix which will fulfill the needs of all customers.
2. Product differentiation – the company that bases its business strategy on product differentiation approach produce two or more different products. These products are distinguished by their attributes, form, size design, etc. Thus for example, Coca – Cola and other non alcoholic producers, produce certain kind of drink packaged in different packaging. These products are produced aiming to offer customers different solutions for fulfilling their needs.
3. Target marketing – in the cases that two previous approaches were argued as inefficient and impractical, the company use market segmentation approach as an efficient method for better fulfilling customer needs. This method has to do with finding out those customers groups which have same needs and wishes during buying products. By

recognizing those customer groups the company can produce products that are destined to only those customers. This approach is illustrated in Figure 2.6. Here the company introduces a new product which in combination with marketing mix instruments is oriented toward specified target market. Thus the company from many segments specifies



Figure 2.6 Market segmentation approach⁷

and chooses one or some of them and develops marketing mix strategy for every segment separately. As an example here, let's take Coca – Cola again, which produces drinks that are destined customers that suffer from diabetes”.

Target marketing requires by marketers to take three major steps⁸:

- Identify and profile distinct groups of buyers who might require separate products or marketing mixes (market segmentation);
- Select one or more market segments to enter (market targeting); and
- Establish and communicate the product's key distinctive benefits in the market (market positioning);

All these stages are depicted bellow (Figure 2.7).

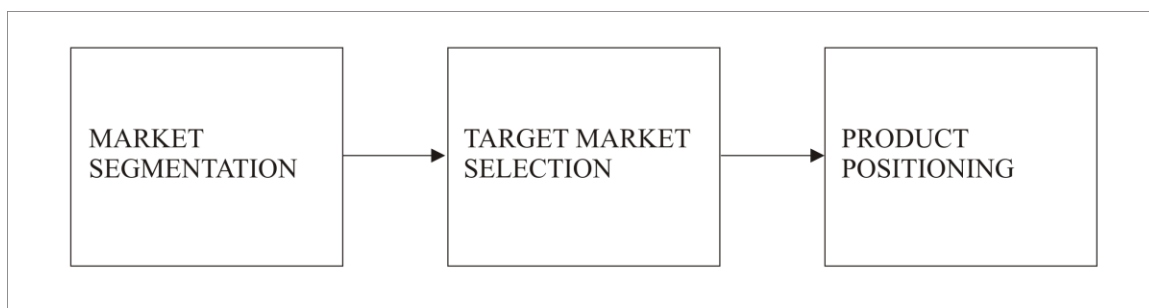

Figure 2.7The stages of marketing mix strategy⁹

The first stage, market segmentation should be based on some criteria. According to Cannon¹⁰, there are two main categories of segmentation criteria: the first is based *on the characteristics of the consumer or user* and the second, called “product segmentation”, *focuses on how consumers or buyers perceive, group together and differentiate between available brands, products or services.*

2.4.3 PATTERNS OF MARKET SEGMENTATION

Given that importance of market segmentation has been pointed out before, now the next step and dilemma for marketers would be possible methods and options in building up these segments. According to Kotler¹¹ one common method is to identify preference segments. Buyers were asked of how much they value sweetness and creaminess in an ice cream as two product's attributes. In his example, three different patterns could emerge:

1. “Homogeneous preferences: Figure 2.8.a shows us a market in which all of the consumers have roughly the same preference, so there are no natural segments. In this case the brands would be similar and cluster around the middle of the scale in both sweetness and creaminess.
2. Diffused preferences: here consumers' preferences may be scattered throughout the space (Figure 2.8.b), indicating great difference in consumers preferences. In this situation, marketers must plan that one brand to be positioned in the center to attract most consumers. While, if several brands are in the market, they are likely to position throughout the space and show real differences to reflect consumer – preference differences.
3. Clustered preferences: the market might reveal distinct preference clusters, called natural market segment (Figure 2.8.c). The first company in this market might position in the center to appeal to all groups, choose the largest market segment (concentrated marketing), or develop several brands for different segments. If the first company has only one brand, competitors would enter and introduce brands in the other segments”.

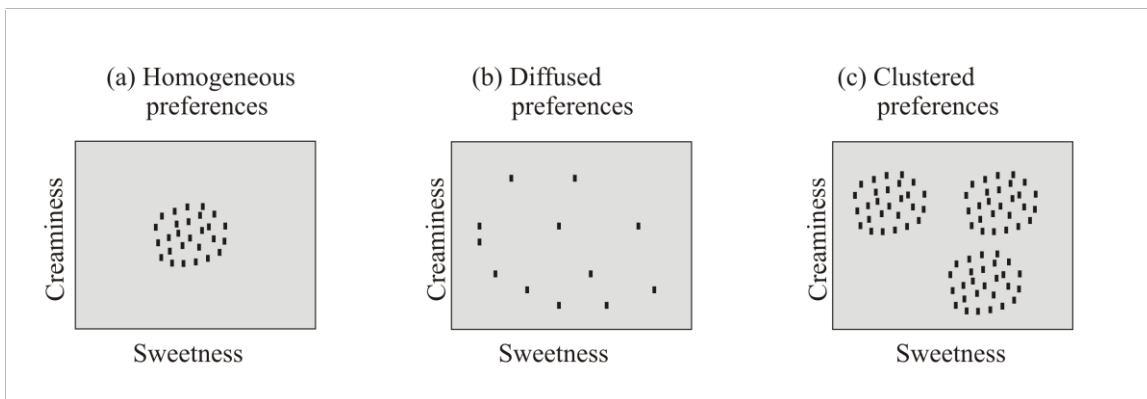

Figure 2.8 Basic Markets – Preference Patterns¹²

2.4.4 MARKET SEGMENTATION PRECEDURE

The previous unit described a method for building up market segments. Also, a method to identify these market segments was provided above. Now we will explain the procedure of identification of market segments. Marketers use a three – step procedure for identifying of market segments¹³:

1. *Survey stage.* The researcher conducts exploratory and focus groups to gain insight into customer's motivation, attitudes, and behavior. Then the researcher prepares a questionnaire and collect data on attributes and their importance ratings, brand awareness and brand ratings, product – usage patterns, attitudes toward the product category, and respondents' demographics, geographic, psychographics, and media graphics.
2. *Analysis stage.* The researcher applies *factor analysis* to the data to remove highly correlated variables, and then applies *cluster analysis* to create a specified number of maximally different segments.
3. *Profiling stage.* Each cluster is profiled in terms of its distinguishing attitudes, behavior, demographics, psychographics, and media patterns, and then to each segment is given a name based on its dominant characteristic. In a study of the leisure market, Andreasen and Belk¹⁴ found six segments: passive homebody, active sports enthusiast, inner – directed self – sufficient, culture patron, active homebody, and socially active. They found that performing arts organizations could sell the most tickets by targeting culture patrons as well as socially active people.

The instructions that could be revealed from this procedure are that to identify the market segments it is necessary to make a market research.

2.4.5 SEGMENTING CONSUMER AND BUSINESS MARKETS

In the first unit of this chapter it was showed the major and inherent difference between consumer and business market. Because of these differences, it is impossible to use exactly the same variables to segment both markets. Variables mentioned here and used for market segmentation “are dimensions of person, group or of company, which are used during breaking down the entire market into segments”¹⁵. Marketers use one group of variables for consumer market segmentation and another group for business market segmentation. As much as more variables are used the number of segments will be increased. In this case the marketing managers should take into account whether additional variables will improve the efficiency of marketing elements or not. By using multiple variables the company will have more exact data but on the other hand will have more costs to find out these additional variables.

2.4.5.1 BASES FOR SEGMENTING CONSUMER MARKETS

According to Kotler, in segmenting consumer markets, marketers can apply geographic, demographic, and psychographic variables related to consumer characteristics as well as behavioral variables related to consumer responses (Table 2-2).

Geographic segmentation – is the division of a total, heterogeneous market into relatively homogeneous groups on the basis of:

- Regions: e.g. South – east Europe region, or in Kosova these might be Prishtina region, Peja region, etc.
- Countries: perhaps categorized by size, development or membership of geographic region, e.g. most industrialized countries, developing countries, third – world countries, etc.
- City / Town size: e.g. population within ranges or above a certain level
- Population density: e.g. urban, suburban, rural, semi-rural
- Climate: e.g. Mediterranean, Southern, etc.

Geographic segmentation is an important process - particularly for multi-national and global businesses and brands. Many such companies have regional and national marketing programs which alter their products, advertising and promotion to meet the individual needs of geographic units.

Demographic segmentation –is an approach used by companies to separate or identify customers by socioeconomic groups, such as location, age, sex, occupation and education. The results are often used to aim marketing and sales campaigns at niche customer groups¹⁶. Here below as an illustration will be shown how certain demographic variables are used to segment consumer market. The following five variables are examples of demographic factors used in market segmentation:

- **Age:** Consumer needs and wants change with age. The marketing mix may therefore need to be adapted depending on which age segment or segments are being targeted. So Marketers design, package and promote products differently to meet the wants of different age groups. For example, there are companies that design automobiles to target the young people, in particular.
- **Life-cycle stage:** Dividing a market into different groups based on which stage in the life-cycle, presented on the Table 2-2, reflects the fact that people change the goods and services they want and need over their lifetime. A consumer's stage in the life-cycle is an important variable - particularly in markets such as leisure and tourism¹⁷.
- **Gender¹⁸:** Gender segmentation is widely used in consumer marketing. Dividing a market into different groups based on sex, has long been common for many products including cosmetics, clothing, hairstyling and magazines. In the 1960's car companies such as Toyota began to realize the purchasing power of women, creating marketing campaigns, and then cars, specifically targeted at the female market. Many suggest that the range of interior and exterior colors schemes, and emphasis placed on safety factors by car manufacturers today, is due to in no little part to their desire to market cars to women, as well as men.
- **Income:** Income segmentation is a long – standing practice in such categories as automobiles, boats, clothing, cosmetics, and travel¹⁹. The income can be taken as a measure of buying potential of consumers, though there are cases where this sentence can not stand as a fully truth. As sometimes there are over privileged segments from each social class that tend to buy high price products.
- **Social class²⁰:** Many Marketers believe that a consumers "perceived" social class influences their preferences for cars, clothes, home furnishings, leisure activities and other products and services. There is a clear link here with income-based segmentation. But the tastes of social classes can change over time. Thus, marketing manager when use this variable should create flexible market segments.

Psychographic segmentation – is the division of a heterogeneous market into relatively homogeneous groups on the basis of their attitudes, beliefs, opinions, personalities and lifestyles. This segmentation sometimes is called "State-of-Mind" Segmentation²¹.

- **Personality:** Term which attempts to aggregate that combination of traits which may indicate what a person will do, or how an individual will behave when placed in given or differing situations. When company uses this variable to segment the market especially when new product is launched, and in particular, opinion leaders may be important in increasing the level of recognition and acceptance of a new product.

- **Lifestyle:** is the division of a total heterogeneous market into relatively homogeneous groups on the basis of their way of life as shaped by their interests, attitudes and opinions²². For example, Cigarettes corporate have produced the different brand of cigarettes, such as cigarettes for “hard smokers”, for “temporary smokers”, and for “light smokers” (Marlboro light). Or, young professionals may drive a sports car because of the image they want to project. Married parents might want the same things, but they have to provide that for their children, and as a result large extra costs are attached. They will need a family car to suit their lifestyle.
- **Values**²³: refers to a single belief that transcends any particular object, in contrast to an attitude, which refers to beliefs regarding a specific object or situation. Values are more stable and occupy a more central position in a person's cognitive system. Values are determinants of attitudes and behavior and provide a stable and inner oriented understanding of consumers. Values within a system refer to a wide array of individual beliefs, hopes, desires, aspirations, prejudices etc. Values provide potentially powerful explanations of human behavior as they serve as standards or criteria of conduct. These tend to be limited in number and are remarkably consistent over time. The value construct can therefore be used to segment the population into homogenous groups of individuals who share a common value system. Although values often differ from culture to culture, Roper Reports has identified six values segments stretching across 35 countries: “strivers (who focus more on material and professional goals), devotees (who consider tradition and duty very important), altruists (who are interested in social issues), intimates (who value close personal relationships and family highly), fun seekers (who tend to be younger and usually male), and creative (who are interested in education, knowledge, and technology)”²⁴.

Behavioral segmentation – here the market is segmented on the basis of consumers’ attitude toward product, use of, or response to a product. “Segmentation systems based on behavioral data emphasize what customers have purchased (clothing, appliances, big and tall sizes, baby clothes, closeout deals). This information can be used along with a product cross-sell analysis to suggest other products they may be interested in²⁵.”

Companies with a comprehensive customer database in place have the best possible source of data for a behavioral segmentation. Because all purchasing data is already in the customer database — or should be — the hit rates will be 100%. Behavioral-based segmentation systems are the best fit for product-driven organizations where product line managers dominate. This type of segmentation is not as useful for individual customer value development. When new customers are acquired, the organization has to wait for them to define themselves via their purchases. Depending on the type of business and its characteristic frequency of purchase and/or seasonality, it could take quite a while to obtain enough purchase information to correctly classify a customer. Even after customers have made a few purchases, all is known is what they've bought. People could be buying things that company sells from another source, but company management has no way of knowing that. Also, this approach does not give the company any insights into how it could influence a customer's purchase decision. In a similar fashion, behavioral segmentation is not as useful in product development efforts because company only knows what the customers have bought, not what they are most likely buying elsewhere or what unattended needs they may have²⁶.

According to Kotler²⁷, which is referred to many marketers, behavior variables are occasions, benefits, user status, usage rate, loyalty status, buyer – readiness stage, and attitude. These

variables serve as a good starting point to segment the market. Let's have a look on these variables:

- **Occasions:** Buyers can be distinguished according to the occasions on which they develop a need, purchase a product, or use a product. For example, air travel is triggered by occasions related to business, vacation, or family, so an airline can specialize in one of these occasions. Thus, charter airlines serve groups of people who fly to a vacation destination.
- **Benefits:** Buyers can be classified according to the benefits they seek. One study of travelers uncovered three benefit segments: those who travel to be with family, those who travel for adventure or education, and those who enjoy the “gambling” and “fun” aspects of travel.
- **User status:** Markets can be segmented into nonusers, ex-users, potential users, first time users, and regular users of a product. The company's market position also influences its focus on which market segment to be more oriented. Depending on the position of the company that has in the market then it is known better in which market segment to focus more.
- **Usage rate:** Markets can be segmented into light, medium, and heavy product users. Heavy users are often a small percentage of the market but account for a high percentage of total consumption. Marketers usually prefer to attract one heavy user rather than several light users, and they vary their promotional efforts accordingly. This has as advantage the lower promotional expenditures, and also it is easier to create marketing mix parameters accordingly than in a case of several light or medium users.
- **Loyalty status:** Buyers can be divided into four groups according to brand loyalty status: (1) hard-core loyalist (who always buy one brand), (2) split loyalists (who are loyal to two or three brands), (3) shifting loyalist (who shift from one brand to another, and (4) switchers (who show no loyalty to any brand). Each market consists of different numbers of these four types of buyers. Thus, a brand-loyal market has a high percentage of hard-core loyalists. Companies that sell in such a market have a hard time gaining more market share, and new competitors have a hard time breaking in. One caution: What appears to be brand loyalty may actually reflect habit, indifference, a low price, a high switching cost, or the non availability of other brands? For this reason, marketers must carefully interpret what is behind observed purchasing patterns.
- **Buyer-readiness stage:** A market consists of people in different stages of readiness to buy a product: Some are unaware of the product, some are aware, some are informed, some are interested, some desire the product, and some intend to buy. The relative numbers make a big difference in designing the marketing program. In Kosovo the more frequent case is that of unaware of the products by customers.
- **Attitude:** Five attitude groups can be found in a market: (1) enthusiastic, (2) positive, (3) indifferent, (4) negative, and (5) hostile. So for example, workers in a political campaign use the voter's attitude to determine how much time to spend with that voter. They may thank enthusiastic voters and remind them to vote, reinforce those who are positively disposed, try to win the votes of indifferent voters, and spend no time trying to change the attitudes of negative and hostile voters.

Table 2-2 Major Segmentation Variables for Consumer Market²⁸

Geographic	
Region	Pacific, Mountain, West North Central, West South Central, East North Central, East South Central, South Atlantic, Middle Atlantic, South West Europe
City or metro size	Sunny Hill, Ulpiana, Dardania
Density	Urban, suburban, rural
Climate	Mediterranean, northern
Demographic	
Age	Under 6, 6-11, 12-19, 20-34, 35-49, 50-64, 65+
Family size	1-2, 3-4, 5+
Family life cycle	Young, single; young, married, no children; young married, youngest child under 6; young, married, youngest child 6 or over; older, married, with children; older, married, no children under 18; older, single; other
Gender	Male, female
Income	Under 100 €, 100€-199€, 200€-399€, 400€-699€, 700€-999€ 1000€-1499€, 1500€-1999€, 2000€ and over
Occupation	Professional and technical; managers, officials and proprietors; clerical, sales; craftspeople; foreperson; operatives; farmers; retired; students; homemakers, unemployed
Education	Grade school or less; some high school; high school graduate; some college; college graduate
Religion	Muslim, catholic, protestant, other
Race	White, Black, Asian, Hispanic
Generation	Baby boomers, Generation Xers
Nationality	Albanian, American, British, French, other
Social class	Lower lowers, upper lowers, working class, middle class, upper middles, lower uppers, upper uppers
Psychographic	
Life style	Straight, swinger, long hairs,
Personality	Compulsive, gregarious, authoritarian, ambitious
Behavioral	
Occasions	Regular occasion, special occasion
Benefits	Quality, service, economy, speed
User status	Nonuser, ex-user, potential user, first-time user, regular user
Usage rate	Light user, medium user, heavy user
Loyalty status	None, medium, strong, absolute
Readiness stage	Unaware, aware, informed, interested, desirous, intending to buy
Attitude toward product	Enthusiastic, positive, indifferent, negative, hostile

2.4.5.2 BASES FOR SEGMENTING BUSINESS MARKETS

It is already said that in order to segment a business market one should use other variables as well. Some consumer market variables are still usable and necessary. Among those variables still to be used will be geographic, benefits sought, and usage rate ones.

Bonoma and Shapiro proposed segmenting business market with the variables shown on Table 2-3. As the variables are presented from up to down, the most important variable is the demographic one.

Table 2-3 Major segmentation variables for business markets²⁹

<p>Demographic</p> <hr/> <ol style="list-style-type: none">1. Industry: Which industries should we serve?2. Company size: What size companies should we serve?3. Location: What geographical areas should we serve?
<p>Operating Variables</p> <hr/> <ol style="list-style-type: none">4. Technology: What customer technologies should we focus on?5. User or non user status: Should we serve heavy users, medium users, light users, or non users?6. Customer capabilities: Should we serve customers needing many or fewer services?
<p>Purchasing Approaches</p> <hr/> <ol style="list-style-type: none">7. Purchasing-function organization: Should we serve companies with highly centralized or decentralized purchasing organizations?8. Power structure: Should we serve companies that are engineering dominated, financially dominated, and so on?9. Nature of existing relationships: Should we serve companies with which we have strong relationships or simply go after the most desirable companies?10. General purchase policies: Should we serve companies that prefer leasing? Service contract? Systems purchases? Sealed bidding?11. Purchasing criteria: Should we serve companies that are seeking quality? Service? Price
<p>Situational Factors</p> <hr/> <ol style="list-style-type: none">12. Urgency: Should we serve companies that need quick and sudden delivery or service?13. Specific application: Should we focus on certain applications of our product rather than all applications?14. Size of order: Should we focus on large or small orders?
<p>Personal Characteristics</p> <hr/> <ol style="list-style-type: none">15. Buyer-seller similarity: Should we serve companies whose people and values are similar to ours?16. Attitudes toward risk: Should we serve risk-taking or risk-avoiding customers?17. Loyalty: Should we serve companies that show high loyalty to their suppliers?

In the business market segmentation, first the company should decide which industries it wants to serve. After that, it must decide the company's size it wants to serve. And another important decision is the geographical areas it wants to offer its services or products.

After demographic variables came the operating variables, that comprises technology, user or non user status, and customer capabilities. From the significance point of view the operating variables follow situational factors and personal characteristics, as are shown on the Table 2-3.

Reference:

- ¹ Kotler P., A Framework for Marketing Management, 2001
- ² Morden A.R., Elements of Marketing, 1993
- ³ Rexha N. and Reshidi,N, Basics of Marketing, 2002
- ⁴ Kotler P., A Framework for Marketing Management, 2001
- ⁵ Kotler P., A Framework for Marketing Management, 2001
- ⁶ Rexha N. and Reshidi,N., Basics of Marketing, 2002
- ⁷ Rexha N. and Reshidi,N., Basics of Marketing, 2002
- ⁸ Kotler P., A Framework for Marketing Management, 2001
- ⁹ Kotler P., A Framework for Marketing Management, 2001
- ¹⁰ Cannon T., Basic Marketing, 1996
- ¹¹ Kotler P., A Framework for Marketing Management, 2001
- ¹² Kotler P., A Framework for Marketing Management, 2001
- ¹³ Kotler P., A Framework for Marketing Management, 2001
- ¹⁴ Kotler P., A Framework for Marketing Management, 2001
- ¹⁵ Rexha N. and Reshidi,N., Basics of Marketing, 2002
- ¹⁶ Source: Mark Songini, M., www.computerworld.com
- ¹⁷ Adopted by: www.tutor2u.net
- ¹⁸ Adopted by: www.tutor2u.net
- ¹⁹ Kotler P., A Framework for Marketing Management, 2001
- ²⁰ Adopted from: www.tutor2u.net
- ²¹ Adopted from: www.en.mimi.hu
- ²² Adopted from: www.en.mimi.hu
- ²³ Adopted by: www.indiainfo.com
- ²⁴ Kotler P., A Framework for Marketing Management, 2001
- ²⁵ Kotler P., A Framework for Marketing Management, 2001
- ²⁶ Adopted by: www.directmag.com
- ²⁷ Kotler P., A Framework for Marketing Management, 2001
- ²⁸ Kotler P., A Framework for Marketing Management, 2001
- ²⁹ Kotler P., A Framework for Marketing Management, 2001

2.5 PRODUCT POLICY

2.5.1 PRODUCT DEFINITIONS

Before going into detail regarding product policy, let's have a look at some definitions related to product. The term service has the same definition, so the terms product and service will be used interchangeably.

The product is defined as something that is capable of satisfying a customer needs or wants¹. Whereas, Kotler points out that **a product is anything that can be offered to a market to satisfy a want or need**, and adds that **products include physical goods, services, experiences, events, persons, places, properties, organizations, information, and idea².** Regarding the same author, the customer will judge the offered product by three basic elements: product features and quality, services mix and quality, and price appropriateness (Figure 2.9).

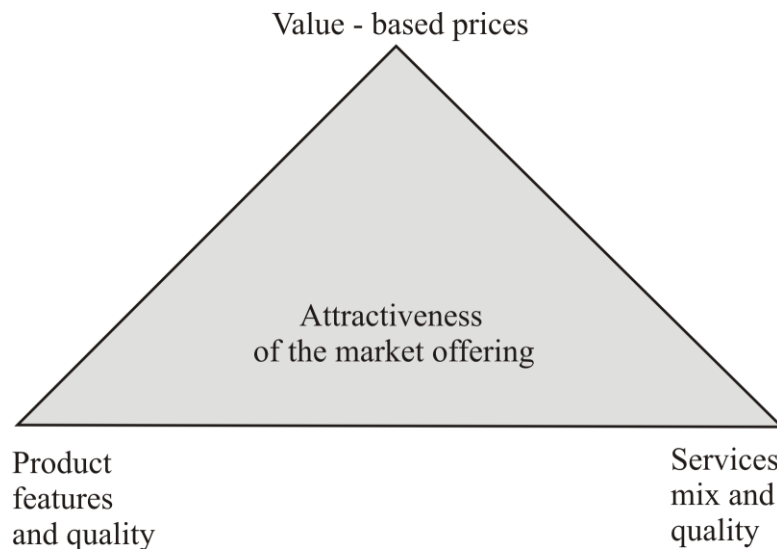

Figure 2.9 Components of the Market Offering³

Another author, Rexha N. defines product as: **Entirety of product is consisted of attributes that make its utilization value and its activities that accompany it toward customers** (Rexha N, 1998)⁴. Rexha splits these attributes into followed groups:

- Product's efficiency: functionality, safety, solidity and durability
- Maintenance and utilization
- Esthetic view, and
- Product's economy

Functionality can be seen as a main factor of determining product's value. But lots of products have more than one function. The main function is called core function. The other functions are called support functions. **Utilization** of product should be taken into account during planning and development of product. The producer should give all of utilization information, aiming that the usage of product to be as easy as possible. The same is worth for **maintenance**. The product should be designed such as to fit the future environment. The product used should be designed for comfort, safety, efficiency, and productivity. **Esthetic**

view has a great significance in customer's perceptions. Especially for product that are used for decoration. **Product's economy** includes the costs that the customer incurs during product's usage.

On the other hand, the customer's needs and wishes are not always well known by the company that offers a product. That customer's needs or wants can be sometimes latent. Hence the company should make some research aiming to offer something that is valuable for customers. First needs to identify who will be interested in buying company's products and services, this should be identified once are analyzed the results of the market research. Market research data will be able to look more closely at what company's targeted market (market segment!) wants and then look at products to see if they are satisfying customer's needs. Then should be examined packaging design, materials used, size and quantity. By analyzing the market and its requirements, company will be able to change the product or develop the product in order to match those requirements of the people products are aiming at. It also needs to remember that customer's needs are likely to change and therefore products should constantly change to reflect each market change, if these changes are ignored then products will no longer be needed or desired by company's target customers. The only way that will be able to do this is to track products and track how customers are still receiving products and services, balancing the subtle changes as they occur.

Kotler suggests that a product should be viewed in three levels (Figure 2.10):

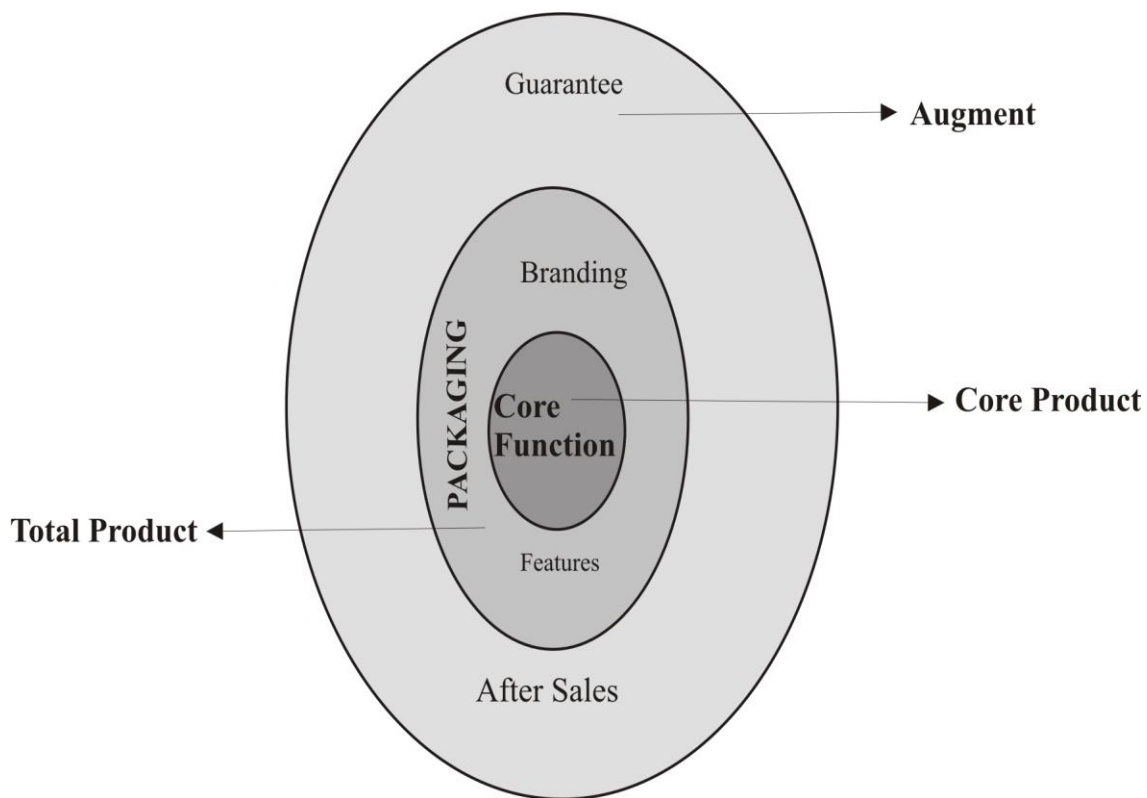

Figure 2.10 Total product⁵

Level 1: Core Function - what is the core benefit a product offers? Customers who purchase a camera are buying more than just a camera they are purchasing memories as well.

Level 2: Packaging - All cameras capture memories. The aim is to ensure that potential customers purchase company's one. The strategy at this level involves organizations branding, adding features and benefits to ensure that their product offers a differential advantage from their competitors.

Level 3: Augmented product - What additional non-tangible benefits can be offered? Competition at this level is based around after sales service, warranties, delivery and so on. So, based on Kotler's view of product, actually it is very difficult to differentiate core function of different manufacturer's product, because virtually no difference exists. The modern concept of augmented product, with its emphasis on quality, features, style, name, packaging, service warranty, installation and instruction, and more recently environmental impact, plays a major part in effective product planning geared to winning real advantages in the market. Differentiating via branding and features in this market is seems to be not enough. The company must be able to make sure that the customer has some form of good quality after core service in the form of warranties, technical back up line and so on. Talking for differentiation of product aiming to create competition advantage, let's point out concludes of UK Department of Trade and Industry regarding Japanese⁶:

Japanese manufacturers in particular are changing the terms of competition. They have moved from competing through low cost and high quality to competing by providing product differentiation and sophisticated multi technology products.

2.5.2 PRODUCT MIX

A product mix (or a product assortment) is the set of all products and items that a company offers for sale, which means that a product mix, is the range of the company's products and brands. All company's products must be designed, developed and produced in full accordance with targeted market segments to which the company has chosen to sell those products. Morden says that the product mix comprises the following elements⁷:

- *Product mix*: which is the complete range of the company's products, services and brands aimed at all of the relevant target markets and market segments.
- *Product line* : which are products, or ranges of products aimed at any one target market or customer type
- *Mix width*: this is the number of Product Lines contained in the Product mix.
- *Mix depth*: is the number of products within any one Product Line.
- *Mix consistency*: describes the relationships between Product Lines within the Product Mix.

2.5.3 THE PRODUCT LIFE CYCLE

To explain what a Product Life Cycle is, let's take a real biological example. A seed is planted (introduction), then it begins to sprout (growth), after it shoots out leaves and puts down roots as it becomes an adult (maturity) and after a long period as an adult the plant begins to shrink and die out (decline). Almost the same happens with "products life". The product itself during its Life Cycle pass through some phases, like as a seed or human being. The product life cycle is consisted of four stages: introduction stage, growth, maturity, and decline stage. All these stages are shown in Figure 2.11.

Morden explain that: “The Product Life Cycle is an important tool for analysis and planning of the marketing activity. It shows the trends in sales and profitability of a particular product over its life cycle”⁸.

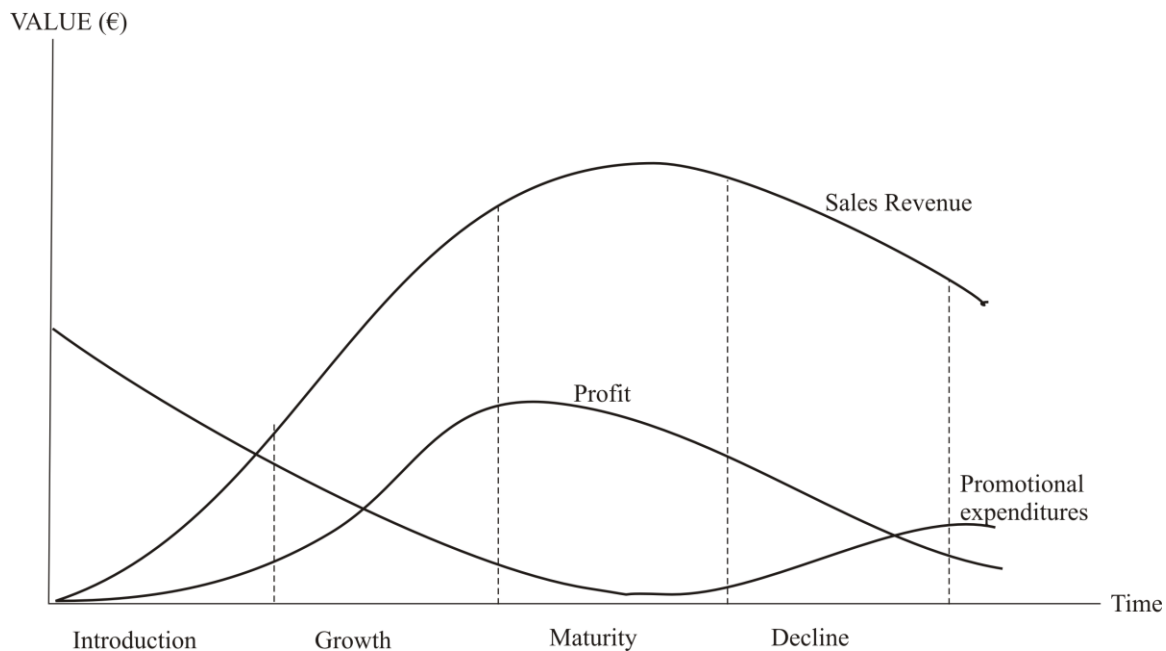

Figure 2.11 Product life cycle⁹

After a period of development it is introduced or launched into the market, it gains more and more customers as it grows. Eventually the market stabilizes and the product becomes mature. Then, after a period of time the product is overtaken by development and the introduction of superior competitors, it goes into decline and is eventually withdrawn. However, most products fail in the introduction stage. Others have very cyclical maturity stages where declines see the product promoted to regain customers.

Introduction stage – this stage will be dominated by the need to establish the product in the market by building buyer and distributor awareness of the product and its benefits¹⁰. Promotional activities are the main tools to create the customer’s awareness about product. Furthermore this will be the initial communication process between the company and customers regarding this new product. Promotional activities may be more informative or educational during this period. To penetrate to the market the company must choose the appropriate initial distribution channels. All of these activities are likely to have to take the form of heavy advertising or promotional expenditures.

Product pricing is the next challenge in this stage. Just premise here that the pricing of new product is the main dilemma on pricing at all (much more about this topic will be covered in “Pricing Policy” chapter 2.6). Referring Table 2-4 the price in this stage can be high or it can choose the penetration strategy. If the customer will be oriented for high prices then this will cover some research and development costs made for other products. If management of company wants to builds up sales volume very quickly then the penetration pricing strategy must be chosen. The need for immediate profit is not a pressure. The product is promoted to create awareness. If the product has no or few competitors, a skimming price strategy is employed.

Table 2-4 Product life cycle stages¹¹

	INTRODUCTION	GROWTH	MATURITY	DECLINE
Sales	Low	Fasts growth	Slow growths	Decline
Profits	Negligible	Peak levels	Declining	Low or zero
Cash Flow	Negative	Moderate	High	Laggardly
Research and Development Costs	Borne by other products	Borne by product	Borne by product, until paid off. Costs of modification or “stretching” may be incurred	Paid off.
Customers	Innovative	Market	Mass market	Latecomers, laggards
Competitors	Few	Growing	Many rivals	Declining numbers
Management objective	Expand market	Market penetration	Defend share, extend duration of stage	Operational productivity, minimise costs
Marketing expenditure	High	High	Adequate to maintain market share and brand loyalty	Low
Marketing emphasis	Product awareness	Brand preference	Brand loyalty	Selected segments
Distribution	Patchy	Intensive	Intensive	Selected outlets
Price	High or penetration(?)	Lower	Lowest	Low or rising (?)
Product	Basic	Improved	Differentiated	Rationalized

As it pointed out in the Figure 2.11, in this stage the profit will be negligible because of high marketing expenditures and low sales volume. On the other hand the product quality is vital during introductory stage as failures during trial of a product can lead to long-term buyer rejection.

Examples - set out below (Table 2-5) are some suggested examples of products that are currently at different stages of the product life-cycle:

Table 2-5 Some products and their PLC stages¹²

INTRODUCTION	GROWTH	MATURITY	DECLINE
Third generation mobile phones	Portable DVD Players	Personal Computers	Typewriters
E-conferencing	Email	Faxes	Handwritten letters
All-in-one racing skin-suits	Breathable synthetic fabrics	Cotton t-shirts	Shell Suits
iris-based personal identity cards	Smart cards	Credit cards	Cheque books

Growth stage – when a new product may begin to enjoy rapid sales growth and begins to bring a profit to a company then this product is entered in its growth stage of its life cycle. If during this stage, the lack of competition exist to market then this stage may become the most profitable stage of the life cycle of the product. According to Canonn, on this stage the management should be focused on¹³:

- A full customer demand base is built in the market
- There is selective building of customer demand at the expense of existing or substitute product types marketed by competitors
- There is the beginning of search for other target market segments into which the product, once modified or further differentiated, can be sold.

In this stage, competitors are attracted into the market with very similar offerings. Advertising spend is high and focuses upon building brand. At this stage, it is cheaper for businesses to invest in increasing their market share as well as enjoying the overall growth of the market. Accordingly, significant promotional resources are traditionally invested in products that are firmly in the Growth Stage.

Maturity stage – The Maturity Stage is, perhaps, the most common stage for all markets. It is in this stage that competition is most intense as companies fight to maintain their market share. The product should be consolidated in this stage and kept differentiated as much as possible. Here, both marketing and finance become key activities. So critical marketing activities need to be managed¹⁴:

- To maintain product distribution and customer access to the product
- To maintain customer loyalty to the brand or product, and hence the rate of repurchase

Marketing spend has to be monitored carefully, since any significant moves are likely to be copied by competitors. The Maturity Stage is the time when most profit is earned by the market as a whole. Any expenditure on research and development is likely to be restricted to product modification and improvement and perhaps to improve production efficiency and quality. As can be seen from Table 2-4, the company may incur some modification costs aiming to “stretch” the duration of the product’s maturity winning new market segments. In this stage profit is declining, because the price must be kept low and promotional expenditures grow.

Decline stage – when sales and profitability start a consistent and perhaps irreversible decline, can be concluded that the product has entered in it decline stage. In the decline stage, the market is shrinking, reducing the overall amount of profit that can be shared amongst the remaining competitors. Once management has recognized and accepted the inevitable of this stage, it can undertake a number of choices, which include¹⁵:

- Withdrawing all expenditures on the product above its variable cost of production, and perhaps raising its price. Demand for the product is then left to wither away, whilst the company diverts the remaining revenues from it towards other products or activities.
- Eliminating the product or service once demand for the product has dropped below a predetermined threshold, particularly that where it is no longer bringing in any contribution (which is the difference between net sales revenue and total variable cost).
- Maintaining production and sale of the product on a restricted basis, for instance in those market segments in which there still some residual brand loyalty. Marketing management may maintain product’s price and quality, protect the product or brand, and await developments. There are two reasons for doing this. The first is that marketers will protect and encourage brand loyal purchasing behavior, since its discouragement can have undesirable knock-on effects elsewhere. The second is the hope that demand for the product may eventually increase again, especially where the market is affected by fashion cycles and trends. At this stage, great care has to be taken to manage the product carefully.

It may be possible to take out some production cost, to transfer production to a cheaper facility, sell the product into other, cheaper markets. Care should be taken to control the amount of stocks of the product. Ultimately, depending on whether the product remains profitable, a company may decide to end the product.

Problems with product life cycle - In reality very few products follow such a prescriptive cycle. The length of each stage varies enormously. Decisions of marketers can change the stage, for example from maturity to decline by price-cutting. Not all products go through each stage. Some go from introduction to decline. It is not easy to tell which stage the product is in.

There are some experts that have pointed out the limitations of using product life cycle model at very case. One of them is Stephen King¹⁶, which pointed out that: “product life cycle can be applied effectively only to a specific form of product or service. Brand can incorporate dramatic changes in composition, sustaining long – term growth, and any attempt to apply the life cycle model is likely to do more harm than good”.

Despite these criticisms, the life cycle model remain an important tool for a company on making analysis, planning, etc. Also, by exploiting this model the company can try to do much more by looking for new product developments, innovations or new market to extend the life cycle (Figure 2.12). While using product life cycle model for cultivating this innovations and invention the company’s management must take care because initial failures can occur. The product life cycle illustrate the importance of adapting a process view of innovation. This means recognizing that “the development of new products is not an instantaneous act but a series of activities that occur over time” (Johne A., 1986). Based on Figure 2.12, when the core product reaches its maturity stage, some analysis regarding this product should taken place by company and based on the result of current product the new product can be launched. Hence the new market can be won, as it depicted in the graph.

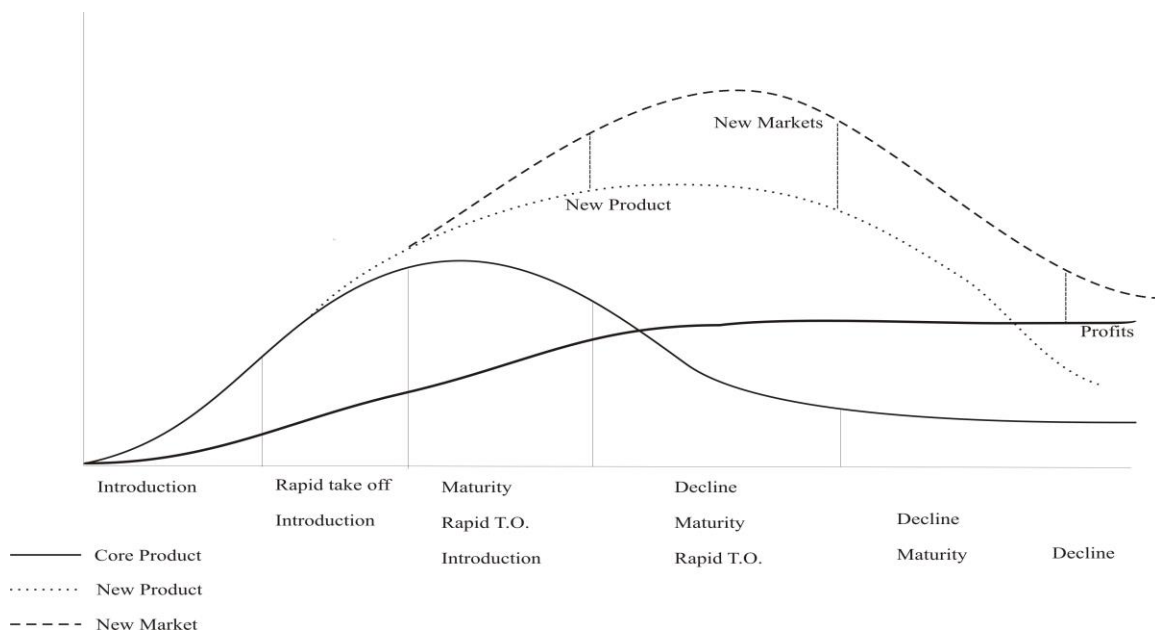

Figure 2.12 Exploiting the product life style¹⁷

2.5.4 INVENTION, RESEARCH AND CREATIVITY

One critical factor within a company, which should not be forgotten especially by managers in Kosovo, is a creative climate that should dominate in relation to employees. This climate can be the source of ideas for development of a new product. In addition, there are of course other sources more of development of a new product, among which Cannon T. ranks¹⁸:

- The company’s research and development department: this department may be working to a specific brief, e.g. to explore a new sources of energy (which is so needed in Kosovo!) or to spot new product opportunities.
- Outside organizations: these can provide continuing source of inventions and developments. They range from governmental projects to private concerns or individuals offering opportunities to license or buy.
- The marketing department and other company units: these can produce leads through such activities as brainstorming, think – tanks, foreign search, market gap analysis, market research, activity analysis, long – range projections and segmentation analysis.

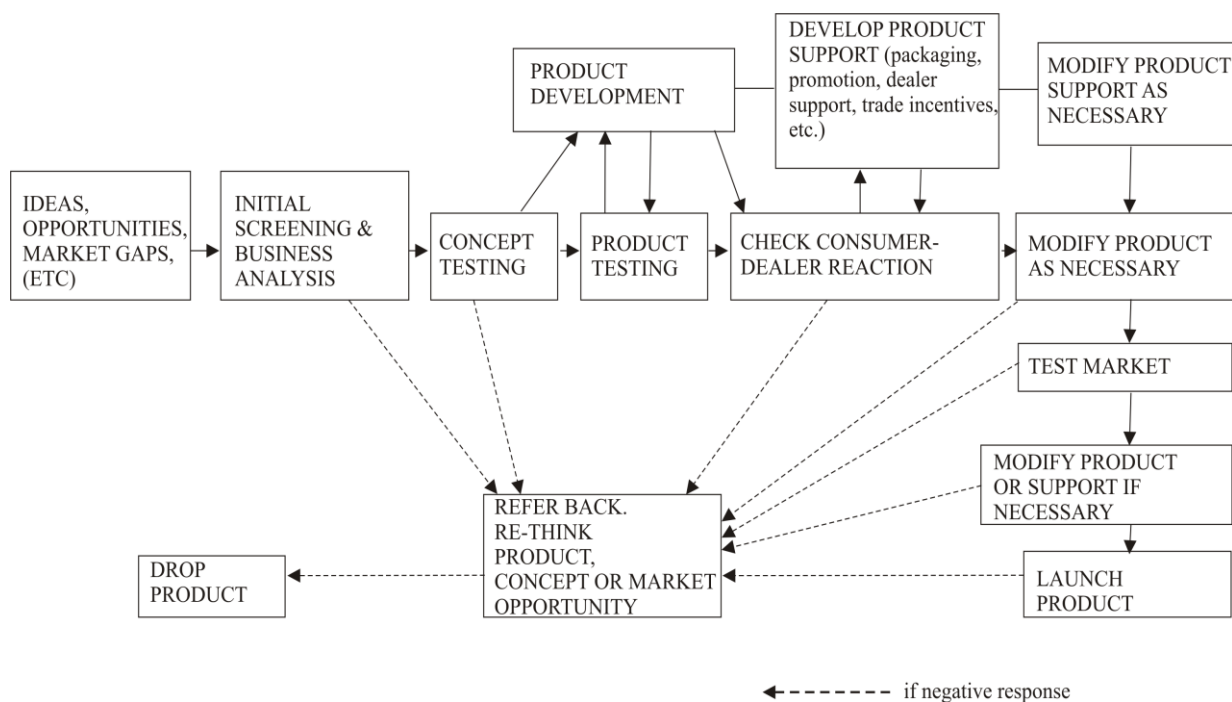

Figure 2.13 The new product development process¹⁹

During these changes regarding inventions the management will face the internal barriers which will emerge for different reasons. The sequence of events in new product development is summarized in Figure 2.13.

2.5.5 INNOVATION

According to Cannon, innovation takes four basic forms²⁰:

- Improvement and development of existing forms: the manufacturer of a piece of earth – moving equipment can introduce features geared to make it operate more quickly or efficiently. An advertising agency may offer new client services.

- Improvement and development of existing processes: a printer may identify ways of printing a specific item to improve finish or reduce price, but calling for only minor modifications, if any, in a client’s layout or presentation.
- Introduction of novel production process: this has been the basis of the growth of industrial society. Suppliers introduce new technologies to the production of basically similar products, often generating dramatic price cuts and improvements in product quality and consistency. From the spinning jenny to the silicon chip, it certainly offers new horizons for the adapting company.
- The introduction of new products and services: in modern society, markets are in a constant state of flux, with modified, changed or revolutionary products or services being offered to potential customers. The craze of skateboard created massive but fleeting opportunities for those fast enough to adapt, and the digital watch threw the Swiss watch industry into confusion, while revitalizing the US industry. The emergence of media buying agencies is forcing many traditional advertising agencies to evaluate their operations carefully, while McDonald’s hamburger franchises have affected the entire fast – food catering market.

All these opportunities for innovation are matched by the risks. It is estimated that between 50 and 90 per cent of new introductions on to the market fail.

2.5.6 BRANDS AND BRANDING

Product and brand management policies were introduced by some larger companies to build the qualities of the small company into the advantages of the larger company. Whereas, The American Marketing Association defines brand as a name, term, sign, symbol, or design, or a combination of these, intended to identify the goods or services of one seller or group of sellers and to differentiate them from those of competitors²¹. However “branding” is actually a very general term covering brand names, designs, trademarks, symbols, etc. “Brand name” refers strictly to letters, words or groups of words which can be spoken.

“Trademark” is a legal term covering words and symbols which can be registered and protected. A legally protected mark can be a very valuable asset and prevent the spread of a market leader’s brand name to generic application, covering a class of products or services²². Whether it is a name, trademark, or another symbol, a brand is essentially a seller’s promise to deliver a specific set of features, benefits, and services consistently to the buyer. According to Kotler²³, a brand is an even more complex symbol and it can convey up to six levels of meaning, as shown on Table 2-6. All these levels are very important when the brand is created. Because, if the company’s management is oriented only in some levels of brand meaning and ignores others as unimportant then the competitor can use exactly those ignored levels and thus create an advantage compared to the company’s product. One mistake that must not happen is to create only attributes and not benefits of product. Because, buyers are not interested in attributes as they are interested in benefits²⁴.

Recently the phenomenon of “own – label” brands has emerged. This specific brand has been created by strong retailing groups in different countries.

According to Cannon, all companies offering an array of products or brands can choose from different of marketing strategies²⁵:

- The entire output can be individually branded, with no obvious generic link.
- There can be a series of family brand within company.

- A powerful brand symbol can link all the company’s offerings, e.g. the Kodak name and symbol are used to link the company’s films, cameras, photographic chemicals and other activities.

Although the brand is powerful tool for the company, it is not preferred to brand without having a vision why and how to brand. The first branding challenge is whether to brand or not, the second is how to handle brand sponsorship, the third is choosing a brand name, the fourth is deciding on brand strategy, and the fifth is whether to reposition a brand later on, as is shown in Figure 2.14

Table 2-6 Levels of Brand Meaning²⁶

Meaning	Description	Example
Attributes	A brand bring to mind certain attributes.	Mercedes suggest expensive, well-built, durable, high prestige vehicles.
Benefits	Attributes must be translated into functional and emotional benefits.	The attribute “durable” could translate into the functional benefit “I won’t have to buy another car for several years”.
Values	The brand says something about the producer’s values	Mercedes stands for high performance, safety and prestige
Culture	The brand may represent a certain culture	Mercedes represents German culture: organized, efficient, high quality
Personality	The brand can project a certain personality	Mercedes may suggests a non-nonsense boss (person) or a reigning lion (animal)
User	The brand suggests the kind of customer who buys or uses the product	Mercedes vehicles are more likely to be bought by 55-year old top managers than by 20-year old ctores clerk

Branding decisions - the first decision has to do whether should the company brand or not. Today almost everything goes branded. There are some products with low quality that goes unbranded even. The brand makes easier for the seller to process orders, it protect the unique product features, allow sellers to attract loyal, offers some protection from competition. Even products such as bananas are branded, although they come from the same places, taste the same, but the branded ones show a differentiated confidence, as better transport services, better maintenance, etc. Then branding helps the seller segment markets by offering different brands with different features for different benefit – seeking segments²⁷. To see how powerful the brand can be, let’s have a look at this true story:

True story²⁸

A test was carried out to establish the influence of brand names. Shoppers were asked which brand they used – consumers who said they used brand A exclusively were given a blind test where they tried both brand A (their supposed favorite) and brand B. Many preferred brand B! Some responders were given brand B marked as brand A. Thinking to be their favorite, they said that they preferred it over their actual favorite.

Kotler suggests that brand allows distributors and retailers to make the product easier to handle, indicate certain quality standards, strengthen buyer preferences, and makes it easier to identify suppliers. On the other hand, customers find that brand names help them distinguish quality differences and shop more efficiently.

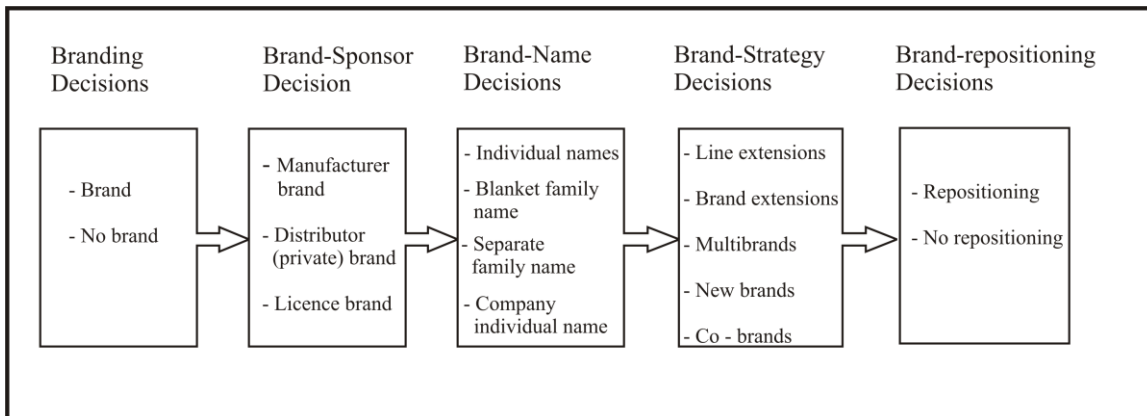

Figure 2.14 An Overview of Branding Decisions²⁹

Brand sponsor decision - According to Kotler, a manufacturer has several options with respect to the brand sponsorship. The product may be launched as a **manufacturer brand** (sometimes called national brand), a **distributor brand** (also called reseller, store, house, or private brand), or a **licensed brand** name. This enables possibilities for retailers and wholesalers to create their own brands, under different conditions in agreement with manufacturer.

Brands name decision – concerning name of the branded product there are four strategies available, whether to choose individual names, blanket family ones, etc, as are shown on Table 2-7. It is very significant to be mentioned that a name goes hand by hand with the image. This is true for the people and for businesses too. Just to remind the big starts of movies and music which have changed their own names? Why? They knew very well this trick, and the effects that this will have to the behavior of human being. Ali³⁰ suggests that companies with the proprietor's name generally do sound like one – person bands. This could put people off. This means the wrong name may prevent customers from getting in touch with the company in the first place. Usually brands relate to products, however, some small companies use their company's brand to sell their products. In connection to relation between a name and an image, it must be mentioned that some names reflect a strong image, while the others a weak one.

Table 2-7 Brand name strategies³¹

Strategy	Examples	Rationale
Individual names	General Mills (Bisquick, Gold Medal, Betty Crocker)	The company does not tie its reputation to the products: if the product fails or seems low quality, the company's name or image is not hurt.
Blanket family names	Campbell's, Heinz, General Electric	The Company spends less on development because there is no need for "name" research or heavy ad spending to create brand-name recognition; also, product sales are likely to be strong if the manufacturer's name is good.
Separate family names for all products	Sears (Kenmore for appliances, Craftsman for tools); Bank One (Bank One for the physical branches, WingspanBank.com for the Internet-based bank).	Where a company offers quite different products, separate family names are more appropriate than one blanket family name.
Company trade name with individual product names	Lellog (Kellog's Rice Krispies, Kellog's Raisin Brain)	The company name legitimizes while the individual name individualizes each product

True story³²

Pepsi wanted to differentiate itself from Coca-Cola. Both brands, and many others, came in red cans. Pepsi decided that rather than attempt to be the same as the brand, it would be a bit different. Although the drink itself did not change, the packaging went from red to blue. This was backed up with extensive fun advertising which showed red things (tomato ketchup, a strawberry, a pillar box) as a blue. Massive media coverage followed. The *Daily Mirror* even published on blue paper on launch day. A simple change in packaging resulted in a clearer identity that helped it stand out from other types of cola.

2.5.7 PACKAGING AND LABELING

Packaging - Most of the physical products should be packaged and labeled before launch into the market. Packaging by many authors is known as a fifth P, but in reality it is just an element of product strategy. Kotler says that packaging includes the activities of designing and producing the container for a product. According to the same author, the following factors have contributed to packaging growing use as a potent marketing tool³³:

- Self service: the supermarket shopper passes by some 300 items per minute. Given that 53 percent of all purchases are made on impulse, an effective package attracts attention, describes features, creates confidence, and makes a favorable impression.

- Customer affluence: rising customer affluence means customers are willing to pay a little more for the convenience, appearance, dependability, and prestige of better packages.
- Company and brand image: packages contribute to instant recognition of the company or brand. Campbell Soup estimates that average shoppers see its red and white can 76 times a year, worth almost as much as of advertising.
- Innovation opportunity: innovative packaging can bring benefits to customers and profits to producers. Toothpaste pump dispensers, for example, have captured 12 percent of the toothpaste market because they are more convenient and less messy.

It obviously seems that product's package or container has several roles or an impact on customer's taking decision whether to buy a product or not. Thus, during designing and producing the products it must take seriously into consideration. Especially when new product is in a developing phase, several packaging decisions are required, as are shown in Figure 2.15. The very first step is to establish the packaging concept, which means that what the package should basically be or do for the specific product. The second step is decision about additional elements such are: size, shape, materials, color, text, and brand mark. It is very important to be mentioned that all these elements must be prior adjusted with product's marketing elements such are price, advertising activities, etc. The final step on decisions concerning new product package is the engineering tests, to ensure that the product can be used normal in a normal conditions. This include visual tests, to ensure that product looks like nice and with harmonized colors; dealer tests, to ensure that product is easy handled by dealers and attractive for them; and finally the most important test is customer test, to ensure that customers are positively responded.

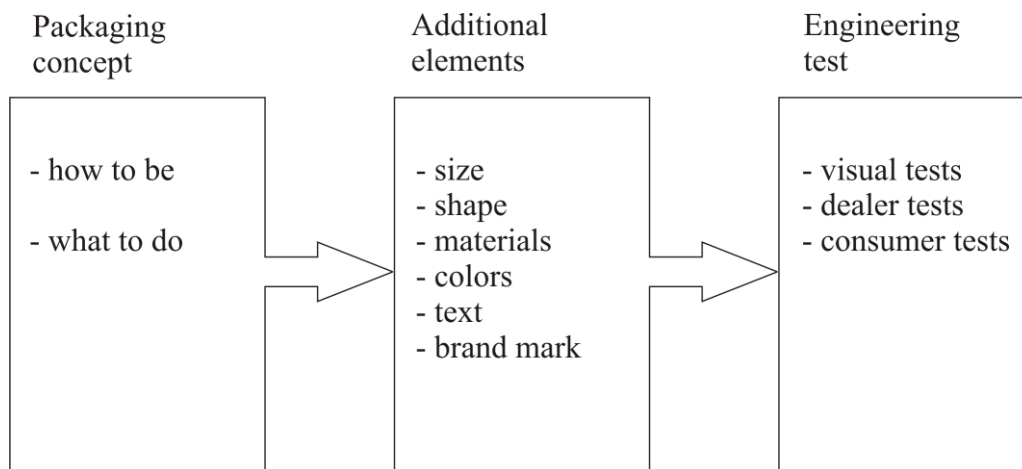

Figure 2.15 New product packaging decisions³⁴

Labeling – label is a simple tag attached to physical product. Labels perform several tasks. First, the label identifies the product or brand, for instance the name Vita stamped on milk. The label might also grade the product, the way that canned Coca –Cola are graded as “light”, or other products that are grade labeled A, B, C. The label might describe the product: who made it, where it was made, when it was made, what it contains, how it is to be used, and how to use it safely. Finally, the label might promote the product through attractive graphics like Children’s games products³⁵.

Reference:

- ¹ Morden A.R., Elements of Marketing, 1993
- ² Kotler P., Framework for Marketing Management, 2001
- ³ Kotler P., A Framework for Marketing Management, 2001
- ⁴ Rexha N. and Reshidi,N., Basics of Marketing, 2002
- ⁵ Kotler P., Principles of Marketing, 1995
- ⁶ Cannon T., Basic Marketing , 1996
- ⁷ Morden A.R., Elements of Marketing, 1993
- ⁸ Morden A.R., Elements of Marketing, 1993
- ⁹ Morden A.R., Elements of Marketing, 1993
- ¹⁰ Morden A.R., Elements of Marketing, 1993
- ¹¹ Kotler P., A Framework for Marketing Management, 2001
- ¹² Adopted from: www.tutor2u.net
- ¹³ Cannon T., Basic Marketing , 1996
- ¹⁴ Cannon T., Basic Marketing , 1996
- ¹⁵ Cannon T., Basic Marketing , 1996
- ¹⁶ King S., “Brand Building in the 1990’s”, 1991
- ¹⁷ Morden A.R., Elements of Marketing, 1993
- ¹⁸ Cannon T., Basic Marketing , 1996
- ¹⁹ Morden A.R., Elements of Marketing, 1993
- ²⁰ Cannon T., Basic Marketing , 1996
- ²¹ Cannon T., Basic Marketing , 1996
- ²² Giles B., Marketing, 1994
- ²³ Kotler P., Principles of Marketing, 1995
- ²⁴ Kotler P., Principles of Marketing, 1995
- ²⁵ Cannon T., Basic Marketing , 1996
- ²⁶ Kotler P., Principles of Marketing, 1995
- ²⁷ Cannon T., Basic Marketing , 1996
- ²⁸ Ali M., Practical Marketing and PR for the Small Business”, 1998
- ²⁹ Kotler P., Principles of Marketing, 1995
- ³⁰ Kotler P., Principles of Marketing, 1995
- ³¹ Kotler P., Principles of Marketing, 1995
- ³² Kotler P., Principles of Marketing, 1995
- ³³ Kotler P., Framework for Marketing Management, 2001
- ³⁴ Kotler P., Framework for Marketing Management, 2001
- ³⁵ Kotler P., Framework for Marketing Management, 2001

2.6 PRICING STRATEGY

2.6.1 PRICE DEFINITIONS

After being familiar with the first marketing mix element, product, now let's discuss in detail the second marketing mix P's – price. *“Price is the amount for which product, service or idea is exchanged, or offered for sale, regardless of its worth or value to a potential purchaser. Although a monetary equivalent or value can be imputed, prices can incorporate goods exchanged, e.g. cars traded in or similar deals”*¹. While another author, Morden says: *“a price is a value or sum of money, at which a supplier of a product or service, and a buyer agree to carry out an exchange transaction”*. According to the same author, the prices at which such exchange transactions take place may either be²:

- Fixed to the buyer: the customer either agree to the price, or does not undertake the purchase;
- Negotiable: in which case the supplier and customer bargain together until they arrive at a mutually agreed price at which the transaction can take place;

Kotler³ adds that whether the price is called rent (for an apartment), tuition (for education), fare (for travel), or interest (for borrowed money), the concept itself remain the same. Among all the marketing mix elements the price is the only one that produces revenues to the company, while other three produce costs. From the above definitions it seems that the nature of price at all is not just money but also the goods.

2.6.2 SETTING THE PRICE

Determining what customers will pay for company's product or service is a critical marketing decision. The right price for company's product or service should be commensurate with the perceived value of the product or service, or customers will be driven to competitors for their product or service. Whole- sale and retail prices, discounts, allowances, and credit terms are key considerations. A company set prices when develops a new product or service, when markets to new customers, and when bids on new contract work. There are many ways to price a product or service. Each of methods or strategies applied should take into consideration the costs of the product or service, the customer's reaction, the intermediary's reaction, the competition's reaction, and the planned profit.

Setting prices is also very much related to the quality of the product. It plays an important role in product's quality positioning. Having in mind this relation between price and quality, in developing its strategy the company will always be in dilemma to decide whether to position its products on price and quality. So always will the competition between the price – quality segments (Figure 2.16).

Now let's have a look at some of extreme price-quality strategies which will help us to have an overview of all other strategies during setting the price⁴:

- **Premium price–quality strategy** - Use a high price where there is uniqueness about the product or service. Means here high price is combined with high product's quality. This approach is used where a substantial competitive advantage exists. Such high prices are charge for luxuries such as Concorde flights.

		PRICE		
		High	Medium	Low
PRODUCT QUALITY	High	1. Premium strategy	2. High - value strategy	3. Super - value strategy
	Medium	4. Overcharging strategy	5. Medium- value strategy	6. Good - value strategy
	Low	7. Rip - off strategy	8. False economy strategy	9. Economy strategy

Figure 2.16 Pricing Strategies Matrix⁵

- **Super value price–quality strategy** -The price charged for products and services is set artificially low in order to gain market share. Once this is achieved, the price is increased. Although the price is low the product’s quality is high, so when the company gains a predefined number of clients which already are used to the company’s products then the price can be increased. The chances to lose clients are very low in this case.
- **Economy price–quality strategy** – Here both the quality and price are kept low. The cost of marketing and manufacture are kept at a minimum. Supermarkets in Kosova often have economy brands for soups, spaghetti, etc.
- **Rip – off price–quality strategy** - Charge a high price because you have a substantial competitive advantage. However, the advantage is not sustainable. The high price tends to attract new competitors into the market, and the price inevitably falls due to increased supply. Manufacturers of digital watches used a skimming approach in the 1970s. Once other manufacturers were tempted into the market and the watches were produced at a lower unit cost, other marketing strategies and pricing approaches were implemented.

According to Kotler, marketers follow six steps to price their products and services. These steps are: 1) selecting the pricing objectives; 2) determining demand; 3) estimating costs; 4) analyzing competitors’ costs, prices and offers; 5) selecting a pricing method; and 6) selecting the final price (Figure 2.17).

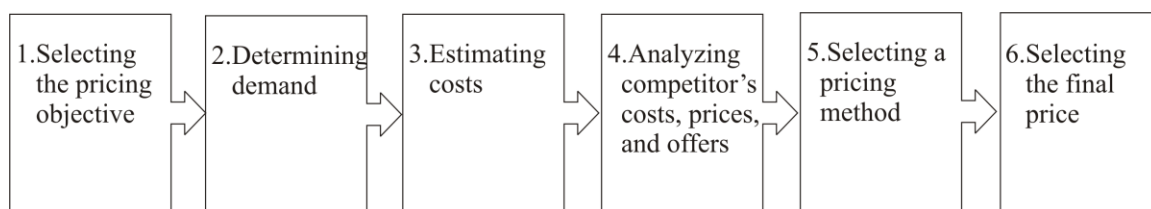

Figure 2.17 Setting Pricing Policy⁶

We are going to discuss bit by bit each of these steps which are very important on assigning the final price.

Selecting the pricing objective- concerning this step, a company can pursue any of five objectives through pricing:

- **Survival-** This is a short-term objective that is appropriate only for companies that are plagued with overcapacity, intense competition, or changing consumer wants. As long as prices cover variable costs and some fixed costs, the company will be able to remain in business. A lot of common restaurants and cafeterias in Kosova achieve this survival objective.
- **Maximum current profit-** To maximize current profits, companies estimate the demand and costs associated with alternative prices and then choose the price that produces maximum current profit, cash flow, or return on investment. However, by emphasizing current profits, the company may sacrifice long-run performance by ignoring the effects of other marketing-mix variables, competitors' reactions, and legal restraints on price.
- **Maximum market share-** some companies choose this objective because they believe that higher sales volume will lead to lower unit costs and higher long-run profit. With this market-penetration pricing, the firms set the lowest price, assuming the market is price sensitive. This is appropriate when: (1) the market is highly price sensitive, so a low price stimulates market growth; (2) production and distribution costs fall with accumulated production experience; and (3) a low price discourages competition.
- **Maximum market skimming-** Many companies favor setting high prices to “skim” the market. This objective makes sense under the following conditions: (1) A sufficient number of buyers have a high current demand; (2) the unit costs of producing a small volume are not so high that they cancel the advantage of charging what the traffic will bear; (3) the high initial price does not attract more competitors to the market; and (4) the high price communicates the image of a superior product.
- **Product-quality leadership-** Some companies aim to be product-quality leaders will offer premium products at premium prices. Because they offer top quality plus innovative features that deliver wanted benefits, these firms can charge more.

Determining demand - each price you charge for a product or service leads to a different level of demand. Therefore, demand largely sets a ceiling to the price you can charge for the product or service. Demand and price are inversely related. High prices usually decrease the demand. But there are cases of high quality products which fulfill the needs of customers and the demand can stay stable, without falling.

Estimating costs - Costs set the floor for your pricing. The price must cover all costs of producing, distributing, and selling the product or service, including a fair return on effort and risk. Consider the following costs⁷:

Cost per Unit of product: this is a variable cost that is duplicated with every unit of product sold. It includes: cost of the product, order processing, shipping and packaging, postage to mail the product, overhead and an allowance for bad debt.

Campaign and Overhead: Costs - these are fixed costs that vary little with changes in the number of products sold. These include:

- Printed materials (cover letter, brochure, etc.) for a direct mail piece
- Mail preparation to stuff envelopes, sort and mail a direct mail piece.
- Postage to send mail pieces
- Advertising costs for display and classified ads.

- Other marketing costs such as telemarketing, the Internet, etc.
- Overhead costs such as accounting and office expenses.

Analyzing your competitor's costs, prices and offers⁸ - while demand sets a ceiling and costs set a floor to pricing, competitors' prices provide an in between point that marketers must consider in setting prices. Learn the price and quality of each competitor's product or service by sending out comparison shoppers to price and compare. Acquire competitors' price lists and buy competitors' products and analyze them. Also ask customers how they perceive the price and quality of each competitor's product or service. If company's product or service is similar to a major competitor's product or service, then the company will have to price close to the competitor or lose sales. If company's product or service is inferior, it will not be able to charge as much as the competitor. Be aware that competitors might even change their prices in response to your price.

Selecting a pricing method⁹ - Given the demand, the costs, and competitors' prices, you are now ready to select a price. These three Cs are the major considerations in setting price (Figure 2.18). The specific price for your product or service will be between one that is too low to produce a profit and one that is too high to produce any demand. The various types of pricing methods are listed below:

Cost-plus Pricing Method: Focus on adding a standard mark- up to the cost of a product.

Target-Profit Pricing Method: Determine the price that would produce the profit you are seeking.

Perceived-Value Pricing Method: Base your price on the products or services perceived value. You use the customers' perception of value, not your costs, as key in this pricing.

Going-Rate Pricing Method: Base the price of your product or service largely on competitors' prices, with less attention on your own costs or demand.

Competitive-Oriented Pricing Method: When you bid for contract work, the competitive-oriented pricing method is appropriate. You base the price for your home-based services on the expectations of how competitors will price rather than on a rigid relation to your costs or demand.

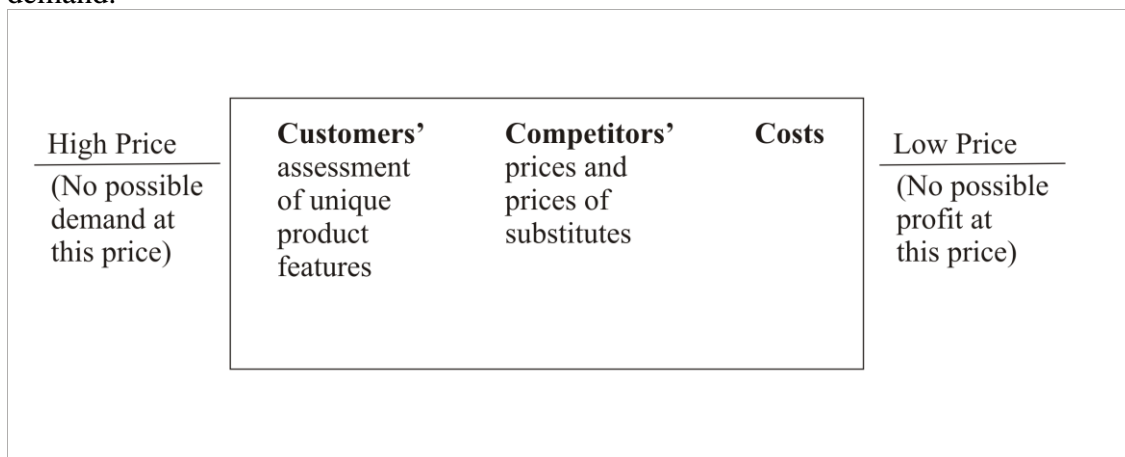

Figure 2.18 The three Cs model for price setting¹⁰

Selecting the final price – the last step in the procedure of setting the product's and service price is to select the final price. Except the previous mentioned methods and factors, the

company should take into consideration additional factors before assigning the price. These factors are psychological pricing, the influence of other marketing mix elements on price and vice versa, the company pricing policy, etc.

Psychological Pricing - Psychological pricing is a theory in marketing that these prices have a psychological impact that drives demand greater than would be expected if consumers were perfectly rational¹¹. Psychological pricing is one cause of price points. This approach is used when the marketer wants the consumer to respond on an emotional, rather than rational basis. For example, customer who see prices at 199 € instead of 200 € will perceive these prices as being in 100 € range rather than in 200 € range. Or in the case of higher-priced cars when from the buyers' point of view are perceived to possess higher quality. Kotler says that: "in general, when information about true quality is unavailable, price acts as a signal of quality"¹². And this is used too much, by too many marketers.

The psychological pricing theory is based on one or more of the following hypotheses¹³:

- Consumers ignore the least significant digits rather than do the proper rounding. Even though the cents are seen and not totally ignored, they may subconsciously be partially ignored.
- Fractional prices suggest to consumers that goods are marked at the lowest possible price.
- Now that consumers are used to psychological prices, other prices look odd.

The theory of psychological pricing is controversial. Some studies show that buyers, even young children, have a very sophisticated understanding of true cost and relative value and that, to the limits of the accuracy of the test, they behave rationally. Other researchers claim that this ignores the non-rational nature of the phenomenon and that acceptance of the theory requires belief in a subconscious level of thought processes, a belief that economic models tend to deny or ignore.

2.6.3 ADAPTING PRICES

According to specific market segments requirements, order levels, purchase timing, guaranties, service contracts and other factors the company are pushed to have a pricing structure rather than to set a single price for their products and services¹⁴. Due to these factors the company should use additional pricing techniques or better saying other price-adaptation strategies, such are: geographical pricing, price discounts and allowances, promotional pricing, and other strategies.

Price Discounts and Allowances - Since price discounts and allowances are most used as price-adaptation strategy, on the **Table 2-8** are shown some price reductions and allowances that falls inside this strategy.

Table 2-8 Price discounts and allowances¹⁵

Cash Discounts	A cash discount is a price reduction to buyers who pay their bills promptly. A typical example is “2/10, net 20,” which means that payment is due within 30 days and that the buyer can deduct 2 percent by paying the bill within 10 days. Such discounts are customary in many industries.
Quantity Discounts	A quantity discount is a price reduction to those buyers who buy large volumes. A typical example is “€ 10 per unit for less than 100 units; € 9 per unit for 100 or more units”. Quantity discounts must be offered equally to all customers and must not exceed the cost savings to the seller associated with selling large quantities. They can be offered on a non cumulative basis (on each order placed) or a cumulative basis (on the number of units ordered over a given period).
Functional Discounts	Functional discounts (also called trade discounts) are offered by a manufacturer to trade-channel members if they will perform certain functions, such as selling, storing, and record keeping. Manufacturers may offer different functional discounts to different trade channels but must offer the same functional discounts within each channel.
Seasonal Discounts	A seasonal discount is a price reduction to buyers who buy merchandise or services out of season. Ski manufacturers will offer seasonal discounts to retailers in the spring and summer to encourage early ordering. Hotels, motels, and airlines will offer seasonal discounts in slow selling periods.
Allowances	Allowances are extra payments designed to gain reseller participation in special programs. Trade-in allowances are price reductions granted for turning in an old item when buying a new one. Trade-in allowances are most common in durable-goods categories. Promotional allowances are payments or price reductions to reward dealers for participating in advertising and sales support programs.

2.6.4 PRICE CHANGE AND CUSTOMER ATTITUDE

Changing the price is not an easy job for marketers either upward or downward. It is especially difficult to change prices upward because of the impact that will affect to competitors, buyers and intermediaries. According to Gilles, B.B. the fact that prices tend to move upward or downward at a particular time may be the result of any of the following¹⁶:

- Unofficial inter company-communications.
- Changes in cost factors which affect all suppliers, such as variations costs and new wage agreements.
- A fear of loss of business if prices are not competitive.
- Action which should have been taken previously, but which has been delayed in order to avoid placing the company in an isolated pricing situation.

Estimating reaction to the price changes - According to the same author to estimate the pre-judging reaction to price changing some of the following methods can be exploited, such are:

- Mathematical models constructed from significant and controllable socioeconomic variable factors.
- Statistical estimates based on regression analysis and simple or multiple correlations.
- Experimental pricing in limited test markets.
- Operations research techniques, such as game theory, to anticipate likely competitive reaction.

Aiming to increase the selling volume, marketers sometimes by mistake think that this can achieve by cutting the prices. But in the paragraphs below there are shown some advices for marketers to do not undersell, for the following six reasons¹⁷:

1. **It may put you out of business:** companies offering knock-down prices are working on very tight margins and relying on a high volume of sale. All it takes is a downturn in your market, even just a slight one, to threaten the life of the business. You can then either put prices up (which makes it even less likely that you will regain your previous sales volume), or cut quality. Once you mess with quality, you are doomed. You will lose credibility, lose customers and lose your business. The moral? Don't sell to cheaply.
2. **It may give you a bad name:** low price is often equated with low quality, so pricing cheap can work against you. Customers might actually pay more for an identical product because they think it must be better.
3. **People buy through need:** it isn't cost that gets people to buy, we buy through need. Your aim is to meet needs by right cost. A cheap car radio is no good if it is too big to fit the slot in your car. An expensive car radio is no good if you can't afford it. A medium-priced one that does the job is just what you need. Aim for pricing is not too cheap, not too expensive, but just right.
4. **It may be unnecessary:** it is possible that you are more "price aware" than your customers. You need to know what their buying habits are. If they are very price conscious and do a lot of shopping around, you have to pay attention to your price. If they don't, you would be a fool to sell to cheaply.
5. **The cheapest doesn't always win:** in tendering, there may be many factors at work, and one of them will inevitably be the price. But being the cheapest may not guarantee you the work. The other benefits you offer may give you an edge. By cutting costs to the bone in order to produce the lowest tender, you might lose out to a company charging a little more, but offering a lot more.

Reference:

- ¹ Cannon T., Basic Marketing , 1996
- ² Morden A.R., Elements of Marketing, 1993
- ³ Kotler, P., A Framework for Marketing Management, 2001
- ⁴ Adopted from: www.marketingteacher.com
- ⁵ Kotler, P., A Framework for Marketing Management, 2001
- ⁶ Kotler, P., A Framework for Marketing Management, 2001
- ⁷ Adopted from: www.marketingteacher.com
- ⁸ Adopted from: www.marketingteacher.com
- ⁹ Adopted from: www.marketingteacher.com
- ¹⁰ Kotler, P., A Framework for Marketing Management, 2001
- ¹¹ Adopted from: www.answers.com
- ¹² Kotler, P., A Framework for Marketing Management, 2001
- ¹³ Adopted from: www.answers.com
- ¹⁴ Kotler, P., A Framework for Marketing Management, 2001
- ¹⁵ Kotler, P., A Framework for Marketing Management, 2001
- ¹⁶ Gilles, G.B., Marketing, 1994
- ¹⁷ Ali, M., Practical Marketing and PR for the Small Business, 1998

2.7 DISTRIBUTION CHANNELS

2.7.1 INTRODUCTION

After discussing the two marketing mix P's, now it will be discussed the third one – Place or distribution channel. Place refers to how the products are made accessible and available to the customer. This chapter will describe the main channel types, and examine some of their advantages and disadvantages.

But what term distribution channel from the perspective of marketing means? Kotler says: “*distribution channels are sets of interdependent organizations involved in the process of making a products or service available for use or consumption*”¹. While another author, Bucklin is expressed: “*A channel of distribution comprises a set of institutions which perform all of the activities utilized to move a product and its title from production to consumption*”². And the last author that will be cited is Morden, which adds: “*distribution channels provide the link between production or supply, and consumption*”³. From the above definitions it is clearly understood that distribution is all about getting your product/service to the right people at the right time with special consideration for profit and effectiveness. Successful marketing does not end when a business has developed a product/service and has found its appropriate target audience with a view to selling it at the right price, but also to the right place¹, which in turn means that the next issue that needs to be faced is how they are going to distribute and sell this product/service to the consumers. When a product/service is purchased by a consumer, it may have been bought directly from the business, or it may have been through a number of intermediaries (wholesaler, retailer, etc). Small businesses need to acknowledge the different types of distribution channels to utilize sales potential. The sales or profit could be increased by using a different distribution channel to the one that the company actually uses. All the time during company's business marketers may take notes of different channel types. Since distribution channels are influenced largely by the type and size of the business, marketers should have in mind all channels possibilities. Because one channel that could not be used for the current business perhaps it can be adopted for the future circumstances or businesses.

2.7.2 DISTRIBUTION CHANNEL ROLE

Before deciding a specific distribution channel the marketers should have a clear picture and marketing objective on what task that chosen channel has to fulfill.

The marketer's channel objectives - These channels of distribution objectives are summarized on Table 2-9. From the table it seems that among other objectives the chosen distribution channel should fulfill are penetration and positioning in the market, maximizing benefits from the chosen channel, channel contribution to the final strategy that supplier has predefined, how does the channel motivate the distributors, etc.,.

The distribution channel advantages - in the process of making the producers' products available to the customers the number of intermediaries are involved. As a consequence some selling jobs have been delegated by producers to the intermediaries. This delegation means relinquishing some control over how and to whom the products are sold; producers gain

several advantages by using channel intermediaries. According to Kotler these advantages are⁴:

- Many producers lack financial resources to carry out direct marketing. For example, Fruti sells its drinks through more than 200 outlets in Kosova.

Table 2-9 Channel of distribution objectives⁵

	OBJECTIVE	SUMMARY
a	Appropriate and adequate distribution	To achieve objectives for market penetration and competitive position
b	Access to the market	To gain access to the target markets, whether on an <i>intensive</i> or <i>selective</i> basis
c	Cost – effectiveness in access to the market	To maximize the benefits obtained from the chosen channel, relative to the costs incurred by using the channel
d	Competitive representation	Will the channel chosen, and the reseller effort that it contains, allow the supplier to implement his or her competitive strategy, relative to competing suppliers? Will the channel actually add competitive advantage to the products or service?
e	Reseller motivation	To motivate the distributor into making the maximum effort on behalf of the supplier's products, and to place them in a priority position within his own reselling strategy
f	Revenue return from resellers	To optimize the revenue returns, given the channel structure chosen, and interdependent effect of other channel objectives on revenue returns obtainable
g	Cost – effective physical distribution	To achieve most cost – effective physical distribution of goods, given the distribution channel chosen
h	Customer service	To offer a cost – effective level of customer service, whilst at the same time maximizing the competitive advantage to be gained from offering consistent and reliable customer service

- Direct marketing simply is not feasible for some products. For example, companies who produce gums would not find it practical to establish their retail gum shops, but rather they find easier to work through a network of privately owned distribution organizations.
- Producers who do establish their own channels can often earn a greater return by increasing their investments in their business. If a company earns 20 percent rate of return on manufacturing and only 10 percent return on retailing, it does not make sense to undertake its own retailing.

Intermediaries through their contact with the target markets achieve superior efficiency in making the goods available and accessible to that specific target market. In the Figure 2.19, there are shown two cases of possible contacts producers - customers. Case a) shows three

producers who establish the direct contacts with each of their three customers, thus creating nine contacts. Whereas in the case b) the relation of three producers with each of their three customers is created by one distributor, who contacts the three customers, for a total of only six contacts. It obviously seems that working through a distributor is more efficient and it costs cheaper from a producer – customer system point of view.

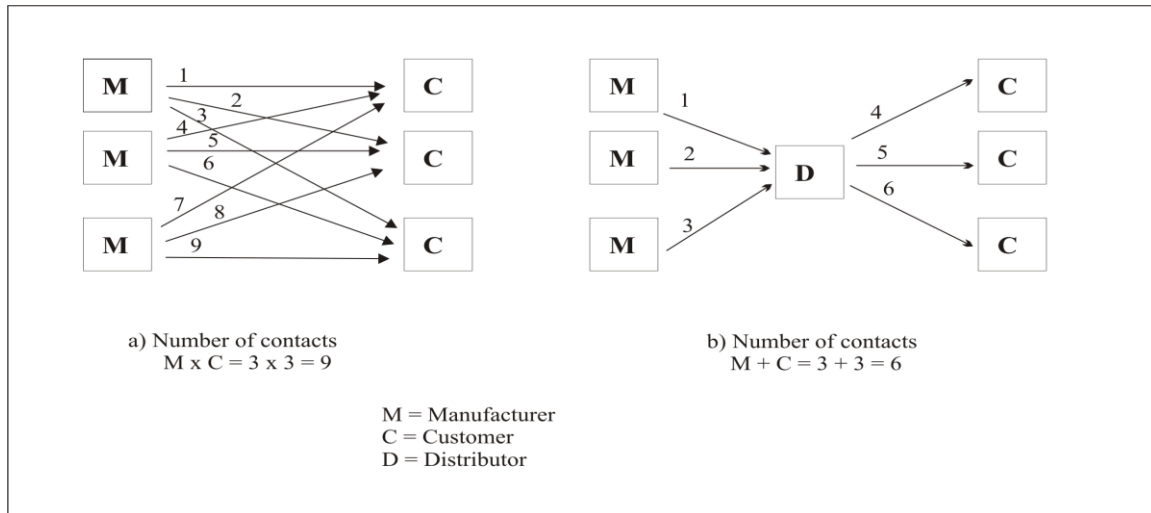

Figure 2.19 How a distributor effects economy of effort⁶

Channel levels – from explanations above, it is very clear that distribution channel connects together both the producer and the customer. This shows us that the supplier and final customer are part of every channel.

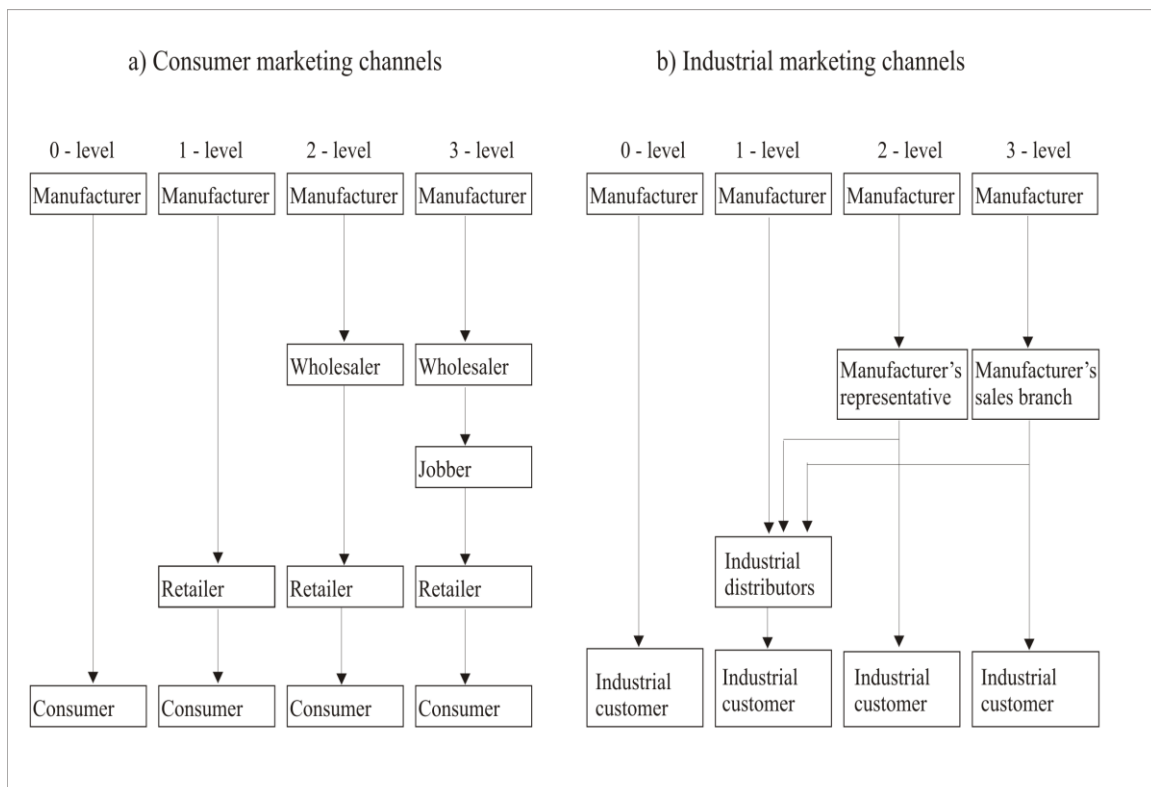

Figure 2.20 Consumer and Industrial Marketing Channels⁷

In the Figure 2.20 are shown cases of consumer – goods marketing channel and industrial marketing channels as well. It seems that a zero – level channel consists of a producers selling directly to their customers (examples of these kinds of channels levels will be given when will be discussed types of intermediaries!). A one – level channel contains one selling intermediary, such are retailers in the consumer market or industrial distributors in the industrial market. While a two – level channel contains two intermediaries; such is the chain of wholesalers – retailers in the consumer market, or chain of manufacturer’s representative – industrial distributors in the industrial market. A three level – channel contains three intermediaries, such as a chain wholesaler – jobber – retailer in the consumer market. As the number of intermediaries increases, it becomes more difficult for the producer to obtain information about the end users, or eventually to exercise any control.

2.7.3 TYPES OF INTERMEDIARIES AND SELLING METHODS

Intermediaries connect producers with the other intermediaries or with the final consumers. According to authors Dibb S. and Simkin L. there are two main types of intermediaries⁸:

- Merchants; and
- Functional intermediaries;

Merchants buy, take title to, and resell the products or services. Examples of such cases are wholesalers and retailers.

While functional intermediaries do not take the title of products, but they search for customers and may negotiate on the producer’s behalf, thus just helping the exchange between producers and merchants or other functional intermediaries, and on turn they gain any compensation. Examples of such cases are agents - brokers, company’s representatives and sales agents. The following explains the different types of intermediaries that are used in the distribution channels⁹:

Retailers – retailing includes all of the activities involved in selling goods or services directly to final customer for personal, non business use. Like for wholesalers, it may be that a company only uses retailers if it manufactures its own products: again, evidencing the larger smaller business. Retailers can promote company’s product by making consumers aware of its availability and by passing on technical information that could encourage the sale. Because there are thousands of retailers located all around the country, they are an excellent intermediary for distributing company’s product to a wide geographical range of consumers. Today, many retailers prefer to buy their products directly from producers as illustrated on the Figure 2.20.a by 1 – level channel instead of going through wholesalers (Figure 2.20.a, 2 – level channel): this is typical of supermarkets. By selling directly to retailers, the added expense of transportation is the only issue. Small businesses account for a high proportion of retailers and so they can often find themselves at the end or in the middle of a distribution channel, where their own channel of selling to a consumer would be direct.

Wholesalers – wholesaling includes all activities involved in selling goods or services to those who buy for resale or business use. It excludes manufacturers and farmers (because they are engaged primarily in production) and retailers. It may be that company only sells to a wholesaler if it manufactures its products: possibly evidencing a larger small business. If this is the case, a wholesaler can be used to distribute company’s products reaching a potentially large number of consumers. The main function of a wholesaler is to provide a link between

the producer (company) and the retailer. The main advantage of selling to a wholesaler rather to retailers is efficiency on handling of these functions¹⁰:

- Selling and promoting: wholesalers provide a sales force that helps manufacturers reach many small business customers at a relatively low cost.
- Buying and assortment building: wholesalers are able to select items and build the assortments their customers need, saving their customers considerable work.
- Bulk breaking: wholesalers can achieve savings for their customers through buying in large lots and breaking the bulk into smaller units.
- Warehousing: wholesalers frequently hold inventories, thereby reducing the inventory costs and risks to suppliers and customers.
- Transportation: wholesalers can often provide quicker delivery because they are closer to buyers.
- Financing: wholesalers often finance customers by granting credit, and they finance suppliers by ordering early and paying bills on time.
- Risk bearing: some wholesalers absorb part of the risk by taking title and bearing the cost of the theft, damage, spoilage, and obsolescence.
- Market information: wholesalers usually supply information to suppliers and customers regarding competitor's activities, new products, price developments, and so on.
- Management services and counseling: wholesalers often help retailers train their sales clerks, suggest improvements to store layouts and displays, and help set up accounting and inventory-control systems. They may also help industrial customers with training and technical services.

Once selling to a wholesaler, there are two ways that company's product will reach the consumer. Firstly, as illustrated by 2 – level channel (Figure 2.20.a), the consumer will buy products from the retailer who has bought directly from the wholesaler - the most common out of the two cases. The other advantages of selling to a wholesaler are that they may have strong links with quality retailers: research will help discover this fact. In addition, because they buy in bulk, it reduces the burden of on-site storage at company's premises reducing overhead costs. Further, wholesalers will also take away the burden of transportation, as they often have their own network of transport delivering goods directly to retailers, which would normally be company's responsibility. The disadvantage of using a wholesaler to distribute company's products is that they cannot market company's products extensively. Further, because they buy in bulk, it is often company will sell at a price much lower than the final retail price. Therefore, the wholesaler will take some of the profit because they will sell on company's products in smaller quantities at a higher price.

Agents/Brokers - an agent or broker will help sell company's product or service, but will not take ownership of what they are selling at any time. They usually work on commission taking a percentage of the total sales made by them. An agency or brokerage will sell company's product or service, for example insurance, tickets for entertainment, accommodation. Agents or brokers can sell producers' product on a scale than extends from producers' business premises and are very useful for expanding producers' business into foreign markets. Perhaps the most common example of an agent would be a travel agency. They never own the holidays or credit the full amount of the sale to their business. Instead, they act as a link between the holiday resort and the consumer, taking a commission on the sales.

Direct (on-site) - very common for small businesses, products or services can be sold directly to the consumer on-site i.e. directly from the shop, office or home by consumers physically

coming into the premises to make a purchase. This can be related with, for example, a village baker or a handmade furniture business where the products are made and sold at the same place. This kind of distribution belongs to zero – level channel on the Figure 2.20. This type of distribution works only when company's target consumers are within the local region and are not based on a wide geographical area.

Direct Mail - also known as a mail shot, this type of marketing can produce sales on a local, national, or even global scale. Company's business would send out, say, flyers, leaflets, brochures or catalogues (often targeted to particular consumers) selling company's product or service. Any interested receivers of the mail would make an order through the contact details/order form that would be included.

Although very effective, there is some cost involved but is considerably cheaper compared to other sources of marketing such as advertising. Poorly targeted mail shots can also damage the image of your business, so be sure that you obtain/build appropriate mailing lists before you adopt the idea. Direct mail can be complied and sent directly from company's business, or companies can use a professional service to distribute its information: at a much higher expense.

Telemarketing - Selling your product or service through telemarketing is not popular in Kosova. Similar to direct mail, telemarketing allows sales to be made on a local, national and global scale, although the costs will increase with the time and distance of phone calls. If any company is trying to make a sale over the phone, many people may never have heard about or seen its product, so a company may decide to use telemarketing to draw people to its shop, office or even web site. If they are interested, then a company can make appointments for them to visit it, so that it can offer them personal assistance and information regarding the product or service.

Extra skills may also be required and it creates the need for more staff. Alternatively, a professional service may be consulted to carry out the task: with an increased cost and/or commission.

Internet (E-commerce) - with the popularity of the Internet ever increasing, it has now become one of the most common ways of doing business: e-commerce. Although e-commerce was often associated more with the larger companies, small businesses have now benefited from joining the bandwagon.

The Internet acts a shop window for company's business where company's particular web site will allow consumers to view or purchase its products or services on-line. The Internet can also be used as a marketing tool, purely promoting company's products, which will aim to result in more sales from other distribution channels (about this will be discussed in more detail in the next chapter).

The Internet can help target consumers worldwide although it may be more feasible for consumers to purchase from within the nation (due to costs of postage or feasibility of using the service). The obvious cost of using the Internet for sales is the original set-up and consistent maintenance, as well as the administration.

2.7.4 USING MULTIPLE CHANNELS OF DISTRIBUTION

When analyzing which distribution channel is best for company's business, the management should not restrict itself to one channel, but instead adopt a number of channels that are

suitable for selling company's product or service efficiently and effectively (if necessary). For example, a business may use a retailer to sell their product and at the same time, use direct mail and telemarketing to further encourage sales: there are a number of feasible combinations.

Choosing the Right Distribution Channel¹¹ - There are several factors affecting how company may decide on the most appropriate distribution channel(s). A few of these are highlighted below:

- Profit and Sales - which channels will maximize sales and profit? Using intermediaries such as agents, retailers and wholesalers can distribute product on a wider scale but can often lead to reduced profit levels. Finding the right balance is the key.
- Product/Service - perishable products such as certain foods (e.g. fruit) usually require direct sales because of their short shelf lives. The same principle applies to fragile products to reduce the amount of transportation and handling.
 - Arguably, services need to be sold direct or through intermediaries that provide a strong link between the consumer and the business such as direct mail, e-commerce or telemarketing. This way the consumer can specifically give their situation or requirements directly to the business so a tailored service can be provided
 - Products of low value that are manufactured in high quantities may be influenced to take a distribution channel involving a wholesaler. This way, it reduces the issue of storage, as wholesalers will buy in bulk
- The Consumer – the question that will arise here is convenience of the consumers to buy from chosen channel. Perhaps the chosen channel can be very appropriate for the company but not for the consumers. So the question is how convenient is it for them to purchase product or service? The second question is in which level the chosen channel will attack company's target market? Means if the target market of the chosen channel and company's one are the same.
- Competition – here should be analyzed that how does direct competition sell their product? Is it effective enough to follow?
- Personal Knowledge or Confidence - do the company knows the different intermediaries well enough to be confident that it is the best option? For example, which retailers have a good reputation and where are they located?

Reference:

-
- ¹ Kotler, P., A Framework for Marketing Management, 2001
 - ² Bucklin, Theory of Distribution Channel Structure, 1966
 - ³ Morden A.R., Elements of Marketing, 1993
 - ⁴ Morden A.R., Elements of Marketing, 1993
 - ⁵ Kotler, P., A Framework for Marketing Management, 2001
 - ⁶ Kotler, P., A Framework for Marketing Management, 2001
 - ⁷ Kotler, P., A Framework for Marketing Management, 2001
 - ⁸ Rexha N. and Reshidi N., Basics of Marketing, 2002
 - ⁹ Adopted from: www.bizhelp24.com
 - ¹⁰ Kotler, P., A Framework for Marketing Management, 2001
 - ¹¹ Adopted from: www.bizhelp24.com

2.8 PROMOTION POLICY

2.8.1 PROMOTION DEFINITIONS

Promotion is the fourth Ps of marketing mix elements. It is the communication process between the company and buyers aiming that company's products and services to be well known by customers.

According to Kotler¹, *promotion includes all marketing system tools which task is to communicate with current and potential buyers.*

While Sudar J. says²: *promotion is a mix of different activities by which company communicates with individuals, groups or society in a way of personal and non personal messages on purpose to match their interest and wishes.*

Promotion can influence in creating a good image for the company. It informs the buyers for the product's characteristics and for the launching of the new products in the market also. Promotion can influence in a great deal the customers in their buying judgments and decisions.

Promotion can be effective depending upon effectiveness of other elements of marketing mix (price, product and place-distribution channel). If the price is high or the distribution channel is inappropriate, then likewise the promotional activities will fail for sure. Thus, promotion cannot cover ineffectiveness of the other marketing elements.

2.8.2 MARKETING COMMUNICATION AND COMMUNICATION THEORY

Since the promotional activities deal with communication activities between company and buyers –marketing communication, all these activities should be first analyzed in terms of communication theory.

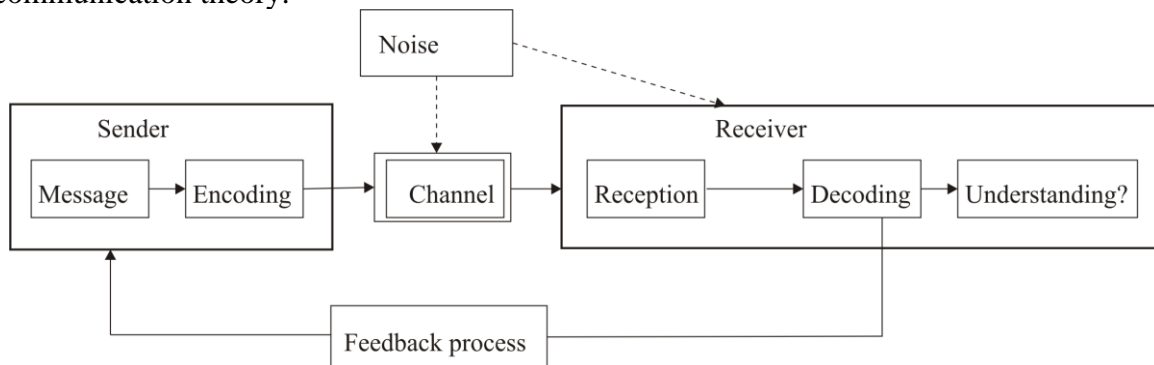

Figure 2.21 The communication process model³

Figure 2.21 shows a message sent by the sender (sender is a given company in marketing communication) as information through the stages of the communication. The message passes through an encoding process made by the sender, and then passes through communication channel, and finally it reaches the receiver where it is the subject of receiving, decoding and possible understanding processes. However, there is no guaranty that the message will be received or understood by the receiver. Even if it is received by the receiver, the message may

be misunderstood (customer can see or hear the promotion made by the company, but it can get rid of it, if the promotion activity is not attractive or appropriate for him).

In the communication theory this happens because during going through communication channel the message is subject of “interferences”. This “interferences” are manifested in the form of⁴:

- *Barriers* such as physical distance; language and cultural differences; inappropriate, ineffective or hostile channels of communication.
- *Filtering* of message content, such that some of the original message is removed.
- *Distortion* of message content, such that the original meaning of the message is changed before it gets to the receiver.
- *Noise* which comprises irrelevant messages or communication which get mixed up with the original message, thereby confusing it or hiding it. Noise is a particular problem for any enterprise involved in transmitting marketing communications. There is so much noise, so much competing communication within external environment that any one message can get lost.

The close analogy exists between the communication theory and marketing communication or promotional activities. It can be demonstrated that all mentioned “interferences” affect almost in the same way the company’s promotional activities.

2.8.3 DEVELOPING EFFECTIVE MARKETING COMMUNICATION

Now it is very clear that communicating with customers is a very sensitive task, in a sense of finding ways, methods or platforms of this interactive dialogue that takes place during pre-selling, selling, consuming, and post consuming stages. The company’s asked sentence “how can we reach our customers”, now it should be associated with the “how can our customers reach us” question one⁵.

Nowadays, sellers use different communication platforms to stay in touch with their customers. On the Table 2-10 there are shown the main communication platforms: advertising, sales promotion, public relations, personal selling and direct marketing (in this chapter will be discussed in more detail for each one).

According to Kotler⁶, there are eight steps to follow in developing an effective marketing communication program: 1) identify the target audience, 2) determine the communication objectives, 3) design the message, 4) select the communication channels, 5) establish the total communication budget, 6) decide on the communications mix, 7) measure the communications’ result, and 8) manage the integrated marketing communication process.

Following will be explained shortly each step of this communication:

1. **Identifying the target audience** – in the target audience are included potential buyers of the company’s products, current users, deciders, or influencers, individuals, groups, particular publics, or the general public. The decisions should be made here about *what* to say, *how* to say it, *when* to say it, *where* to say it, and to *whom* to say it. Prior making these decisions it is better to make an analysis that helps the company assess the audience’s current image of the company, its products, and its competitors. The level of adjusting these five factors is related directly with the customers’ reaction.
2. **Determining the communication objectives** – after that the target audience and its perceptions has been identified, now the marketers can decide on desired audience

response, seeking a *cognitive, affective, or behavioral* response. By these desired audience responses, the marketers want to put something into the customer's mind, change an attitude, or get the customer to act. In the Figure 2.22, there are shown the four best-known models of consumer-response stages. According to this figure, all customers pass through a cognitive, affective, and behavioral stage.

Table 2-10 Common communication platforms⁷

Advertising	Sales Promotion	Public Relations	Personal Selling	Direct Marketing
Print, broadcast, on-line ads	Contests, games, sweepstakes, lotteries	Press kits	Sales presentations	Catalogs
Packaging	Premium, gifts	Video news releases	Sales meetings	Mailings
Motion pictures	Sampling	Speeches	Incentive programs	Telemarketing
Brochures, booklets	Fairs, trade Shows	Seminars	Fairs and trade shows	Electronic shopping
Directories	Demonstrations	Annual reports		TV shopping
Billboards, posters	Coupons	Charitable donations		Fax mail
Display signs	Rebates	Sponsorship		E-mail
Point-of-purchase displays	Low-interest financing	Publications		Voice mail
Audiovisual material	Trade-in allowances	Community relations		
Symbols and logos	Continuity programs	Lobbying		
Videotapes	Tie-ins	Identity media		
Web sites and banners		Special events		

- 3. Designing the message** – now it's time to design the effective message. According to Kotler, in the ideal case, the message should gain attention, hold interest, arouse desire, and elicit action (**AIDA** model, see the first column of the Figure 2.22). Another model (see the second column of Figure 2.22) – hierarchy-of-effects take the target audience all

the way from awareness through purchase. But, anyway AIDA model is most proper one for any communication.

		Models			
Stages	AIDA Model	Hierarchy-of-Effects Model	Innovation-Adaption Model	Communications Model	
Cognitive stage	Attention ↓	Awareness ↓ Knowledge ↓	Awareness ↓	Exposure ↓ Reception ↓ Cognitive response ↓	
Affective stages	Interest ↓ Desire ↓	Liking ↓ Preference ↓ Conviction ↓	Interest ↓ Evaluation ↓	Attitude ↓ Intention ↓	
Behavior stages	Action	Purchase	Trial ↓ Adaption	Behavior	

Figure 2.22 Response Hierarchy Models⁸

4. **Selecting communication channels** – now effective message has been designed. Next step is to select the proper communication channel to communicate with targeted audience. Companies can use two types of communication channels: *personal* and *non personal* one. Personal communication channels involve two or more persons communicating directly with each other face to face, person to audience, over the telephone, or through email. While non personal communication channels include media, atmospheres, and events.
5. **Establishing the marketing communication budget** – company’s expenditures on promotion differ in industrial and consumer market. According to Kotler, there are four common methods for companies to decide on the promotion budget⁹:
 - *Affordable method*: setting the promotion budget at what management thinks that company can effort. This method ignores the role of promotion as an investment.
 - *Percentage-of-sale method*: setting promotion expenditures at a specified percentage of sales (either current or anticipated) or of the sales price. This method views sales as the determiner of the promotion rather than as a result.
 - *Competitive- parity method*: setting the promotion budget to achieve share-of-voice parity with competitors. But, there is no ground to believe that competitors

know better what should be spent on promotion. The company should have its plans and analysis on this.

- *Objective-and-task method*: the promotion budget is set based on the specific company's objectives, determining the tasks that must be performed to achieve these objectives, and estimating the costs of performing these tasks.

6. **Developing and managing the marketing communications mix** – after deciding on the promotion budget, company must decide how to allocate this budget over the five promotional tools: advertising, sales promotion, public relations, personal selling and direct marketing. Companies must consider several factors in developing their promotion mix¹⁰:

- *Type of product market*: sales promotion is used more in consumer market than industrial one. In the Figure 2.23, there are shown the usage of different promotional tools in consumer and industrial market.
- *Push-versus-pull strategy*: a *push strategy* involves the manufacturer using sales force and trade promotion to induce intermediaries to carry, promote, and sell the product to end users. While a *pull strategy* involves a manufacturer using advertising and consumer promotion to induce consumers to ask intermediaries for the product, thus inducing the intermediaries to order it.
- *Buyer-readiness stage* – promotional tools vary in their expenditures at different buyer readiness stages (Figure 2.23). Advertising and publicity play the most important roles in the awareness-building stage. Customer comprehension is affected primarily by advertising and personal selling, while customer conviction is influenced mostly by personal selling.
- *Product-life-cycle stage* - tools vary in their expenditures at different product life cycle stages (Figure 2.23). Advertising and publicity are most cost effective in the introduction stage. Sales promotion, advertising, and personal selling grow more important in the maturity stage. In the decline stage, sales promotion continues strong, advertising and publicity are reduced, and salespeople give the product only minimal attention.
- *Company market rank* – market leaders derive more benefit from advertising than from sales promotion. Conversely, smaller competitors gain more by using sales promotion in their marketing communication mix.

7. **Measuring results** – the last step is to measure the communication effects. The marketers should ask the audience whether they saw, recognize the message, how they felt about message.

8. **Managing the integrated marketing communication process** – evaluating the roles of a variety of communication disciplines, such are: general advertising, direct response, sales promotion and public relations and combining these disciplines to provide clarity, and consistency.

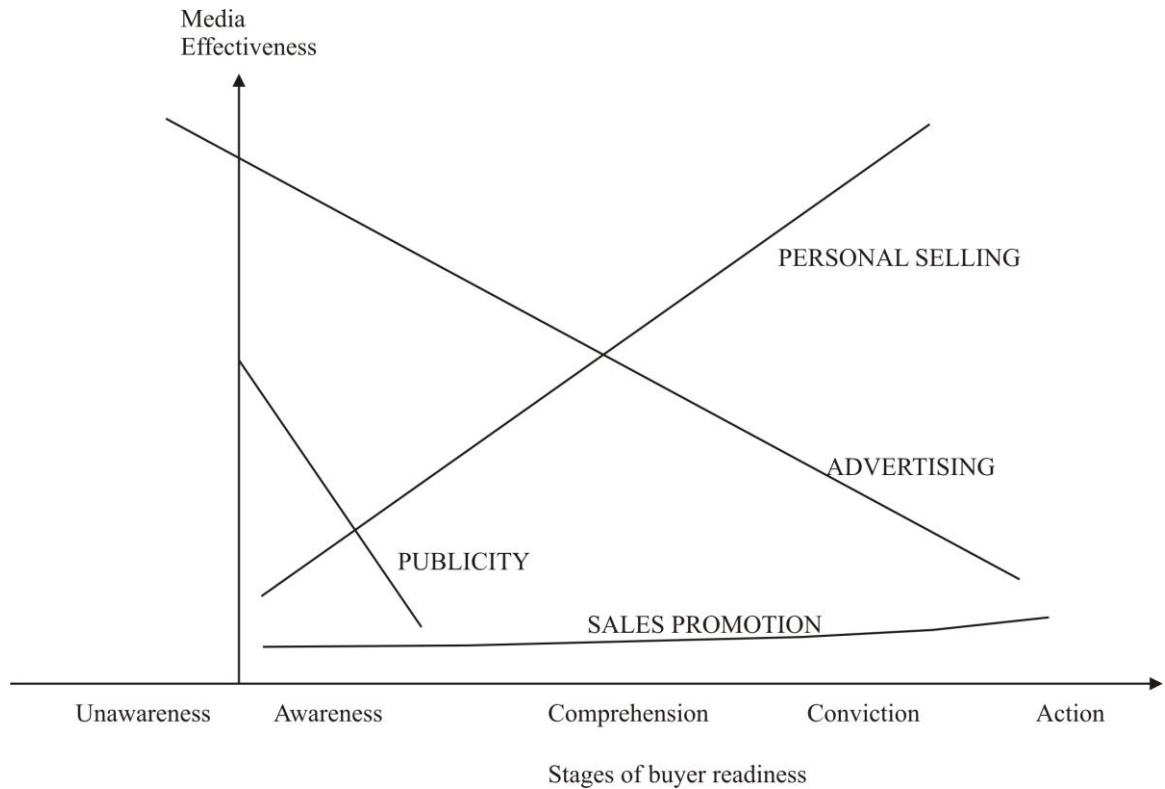

Figure 2.23 Cost effectiveness of different promotional tools at different buyer-readiness stages¹¹

Following will be discussed in detail about promotional mix tools: advertising, sales promotion, public relations, personal selling and direct marketing.

2.8.4 ADVERTISEMENT

Advertisement is one of the fourth activities in a promotion mix. In order to assess its significance in the business of a company, first will be given some definitions on what advertisement is. It is very difficult to find a general accurate definition about advertisement, due to its complex role.

According to Billes, *advertisement is non-personal communication directed at target audiences through various media in order to present and promote products, services and ideas¹².*

Another author, Dinter¹³ says: *advertisement is integral actions which by visual, acoustic or combined messages inform customers about specified products and services and influence them to buy those products or services.*

Here author emphasizes the terms *information* and *influence*. By *information* potential and company's customers can be informed about existing, features and other attributes products. While by *influence* the customers can change their attitude related to company's products or services. Generally speaking, advertising is the paid promotion activity of goods, services, companies and ideas by an identified sponsor.

Kotler¹⁴ says that in developing an advertising program, successful companies start by identifying the target market and buyer motives. And then, according to the same author, the companies can make five critical decisions, known as the five Ms: *Mission*: What are the

advertising objectives? *Money*: How much can be spent? *Message*: What message should be sent? *Media*: What media should be used? *Measurement*: How should the results be evaluated? All these five decisions are shown in Figure 2.24. Marketers see advertising as part of an overall promotional strategy.

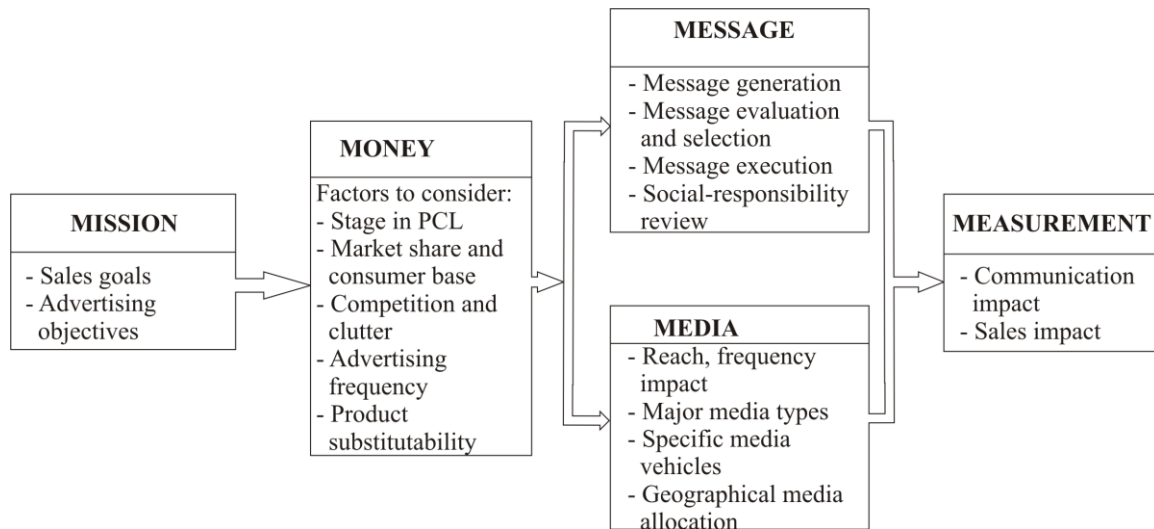

Figure 2.24 The five Ms of Advertising¹⁵

2.8.4.1 ADVERTISING OBJECTIVES

One of the objectives of advertising is to stimulate demand for a product, service, or idea. Where as marketing aims to identify the market that has use for a product, advertising is the communication by which information about the product is transmitted to those individuals. For example, an author, Colley¹⁶ counts fifty two possible objectives of advertisement. Advertising usually seeks to find a potential and current customers and eventually to provoke their interest for any product and thus to communicate and sell to customer. In the face of increased competition within the market due to growing numbers of product substitute via advertising the company should differentiate its products from the competition. The products' branding attributes should be provided in the advertisement. This branding attributes a certain personality or reputation to a brand, termed brand equity, which is distinctive from its competition¹⁷.

Brand franchise is a major way advertising may stimulate demand for a product. When enough brand equity is created that the brand has the ability to draw buyers (even without further advertising), it is said to have brand franchise. The ultimate brand franchise is when the brand is so prevalent in people's mind (called mind share), that it is used to describe the whole category of products. This phenomenon is commonly known as "hyper branding.". A brand franchise can be established to a greater or lesser degree depending on product and market. In almost every market, for example, it is common to hear people refer to *any* soft drink as a Coke, regardless of whether it is actually produced by Coca-Cola or not (more accurate terms would be 'cola' or 'soda')¹⁸. A legal risk of the brand franchise is that the name can become so widely accepted that it becomes a generic term, and loses trademark protection. Examples include "escalator", "aspirin" and "mimeograph".

Other objectives include short or long term increases in sales, market share, awareness, product information, and image improvement.

2.8.4.2 ADVERTISING BUDGET

Before issuing an advertisement, management should consider five factors¹⁹:

- *Product life cycle stage*: new products typically receive large budgets to build awareness and to gain customer trial.
- *Market share and consumer base*: high-market-share brands usually require less advertising expenditure as a percentage of sales to maintain their share. To build share by increasing market size requires larger advertising expenditures. On a cost-per-impression basis, it is less expensive to reach consumers of a widely used brand than to reach consumers of low-share brands.
- *Competition and clutter*: in a market with a large number of competitors and high advertising spending, a brand must advertise more heavily to be heard.
- *Advertising frequency*: the number of repetitions needed to put across the brand's message to customers has an important impact on the advertising budget.
- *Product substitutability*: brands in a commodity class (cigarettes, beer, soft drinks) require heavy advertising to establish a differential image. Advertising is also important when brand offers unique benefits or features.

2.8.4.3 ADVERTISING MEDIA

Advertising messages are transmitted to potential customers through different communication media. All media have their own specifics, so it is very important for marketers to take care on choosing media. In Figure 2.25 there are shown main advertising media.

Some commercial advertising media include billboards, street furniture components, printed flyers, radio, cinema and television ads, web banners, Web Popup, bus stop benches, magazines, newspapers, sides of buses, musical stage shows, stickers on apples in supermarkets, the opening section of streaming audio and video, and the backs of event tickets and supermarket receipts. As was said previously, any place an "identified" sponsor pays to deliver their message through a medium is advertising. Covert advertising embedded in other entertainment media is known as product placement.

Below will be given a short overview of main advertising media, such are television, radio, Newspapers, WWW, new media:

Television - is generally considered the most effective mass-market advertising format. It combines sight, sound and motion. Advantage of using TV is its high reach, and high attention. And this is reflected by the high prices TV networks charge for commercial airtime during popular TV events. As a disadvantage of using TV is its high cost.

Radio – is another important mass media. This media enables to communicate via voice messages to customers. It has high geographic and demographic selectivity, and low cost. But, its limitations are audio presentation only, lower attention than TV, etc. Based on the empiric researches made in some counties it was found out that radio programs are likely to be heard more when they are combined with advertising messages.

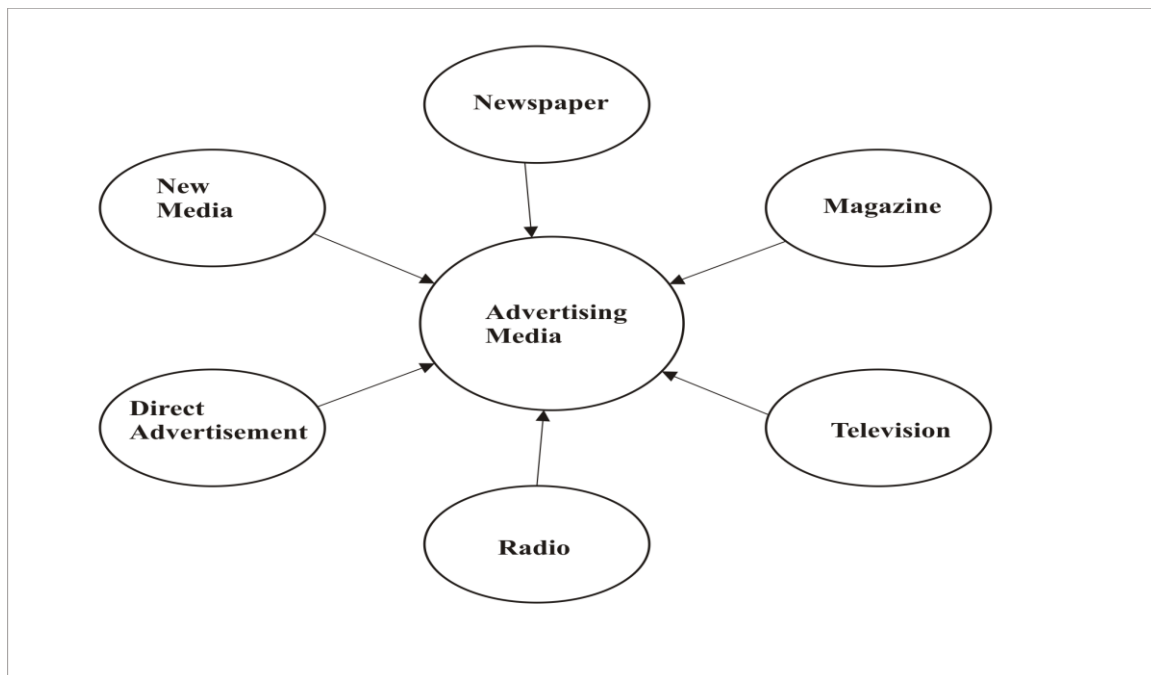

Figure 2.25 Main advertising media²⁰

Newspapers – are very useful mass media tool. Usually, newspapers enjoy a great deal of confidence by their readership.

Advertising on the World Wide Web- recently researches show that internet is the mass medium. According to *Internet Monitor*²¹, people claim to spend 70 per cent more time using the internet in an average week than they do reading magazines or newspapers. What is more, a third of all internet users listen to the radio or watch TV while they surf the net. The younger the user, the more likely they are to do this.

The key to advertising effectiveness on the internet is to involve customers so that they interact with the advertising, because today, it is customers not the seller who is in control. “Customers initiate contact with the seller. They want information the way they want it, when they want it, where they want it. They want customized content. They want relationships and a sense of community. And they want it now”²².

Prices of Web-based advertising space are dependent on the "relevance" of the surrounding Web content. E-mail advertising is another recent phenomenon. Unsolicited E-mail advertising is known as "spam".

2.8.4.4 ADVERTISING MESSAGE AND TECHNIQUES

Spending a lot on advertising does not guarantee success. Research suggests that the clarity of the advertising message is often more important than the amount spent. The advertising message must be carefully targeted to impact the target customer audience. A successful advertising message should have the following characteristics²³:

- **Meaningful** - customers should find the message relevant
- **Distinctive** - capture the customer's attention.

- **Believable** - a difficult task, since research suggests most consumers doubt the truth of advertising in general.

Advertisers use several recognizable techniques in order that by their message better convince the public to buy a product. These may include²⁴:

- **Repetition** - some advertisers concentrate on making sure their product is widely recognized. To that end, they simply attempt to make the name remembered through repetition.
- **Bandwagon** - by implying that the product is widely used, advertisers hope to convince potential buyers to "get on the bandwagon."
- **Testimonials** - advertisers often attempt to promote the superior quality of their product through the testimony of ordinary users, experts, or both. "Three out of four dentists recommend..." This approach often involves an appeal to authority.
- **Pressure**: By attempting to make people choose quickly and without long consideration, some advertisers hope to make rapid sales: "Buy now, before they're all gone!"
- **Appeal to emotion** Various techniques relating to manipulating emotion are used to get people to buy a product. Apart from artistic expression intended to provoke an emotional reaction (which are usually for associative purposes, or to relax or excite the viewer), three common argumentative appeals to emotion in product advertising are wishful thinking, appeal to flattery, and appeal to ridicule. Appeals to pity are often used by charitable organizations and appeals to fear are often used in public service messages and products, such as alarm systems or anti-bacterial spray, which claim protection from an outside source. Finally, appeals to spite are often used in advertising aimed at younger demographics.
- **Association**: Advertisers often attempt to associate their product with desirable imagery to make it seem equally desirable. The use of attractive models, a practice known as sex in advertising, picturesque landscapes and other alluring images is common. Also used are "buzzwords" with desired associations. On a large scale, this is called branding.
- **Advertising slogans** These can employ a variety of techniques; even a short phrase can have extremely heavy-handed technique. For example, Ford's slogan "*We want you to think about buying a Ford*" is an extreme pressure tactic directed straight at the viewer, and McDonalds' slogan, "*I'm loving' it*" is a combination of many different techniques, including a variety of associative responses ("it" invokes both the brand and product, as well as the slogan already being a popular phrase), and cognitive dissonance: The pronoun "I'm" causes dissonance—there is no "I" in the context—and viewer will compensate to reduce dissonance by acceptance of the phrase as one's own idea.
- **Controversy**, as in the Benetton publicity campaign.
- **Guerilla Advertising**: Advertising by association. Done in such a way so the target audience does not know that they have been advertised to, but their impression of the product is increased (or decreased if that is the intent of the advertiser).
- **Subliminal messages**: It was feared that some advertisements would present hidden messages, for example through brief flashed messages or the soundtrack that would have a hypnotic effect on viewers ('Must buy car. Must buy car.'). The notion that techniques of hypnosis are used by advertisers is now generally discredited.

2.8.5 PERSONAL SELLING

Personal selling is of critical importance to the marketing mix. Its objective is to make the sale. Personal selling is a key element in promotion, one of four Ps in the marketing mix. It can be defined as follows:

Personal selling is oral communication with potential buyers of a product with the intention of making a sale. The personal selling may focus initially on developing a relationship with the potential buyer, but will always ultimately end with an attempt to "close the sale"²⁵.

Another explanation of personal selling says: *The personal selling is the form of promotion that uses planned, personalized communication in order to influence purchase decisions and to ensure satisfaction²⁶.*

Personal selling is one of the oldest forms of promotion. It involves the use of a **sales force** to support a **push strategy** (encouraging intermediaries to buy the product) or a **pull strategy** (where the role of the sales force may be limited to supporting retailers and providing after-sales service).

Main advantages of using personal selling - But, what are the advantages of using personal selling as a means of promotion? The main advantages of using it are²⁷:

- Personal selling is a face-to-face activity; customers therefore obtain a relatively high degree of personal attention.
- The sales message can be customized to meet the needs of the customer.
- The two-way nature of the sales process allows the sales team to respond directly and promptly to customer questions and concerns.
- Personal selling is a good way of getting across large amounts of technical or other complex product information.
- The face-to-face sales meeting gives the sales force chance to demonstrate the product.
- Frequent meetings between sales force and customer provide an opportunity to build good long-term relationships.

Main disadvantages of using personal selling - but, as a disadvantage of using this promotional method is its cost. It is the most expensive in terms of achieving sales *as a proportion of number of potential customers reached*. Also sales people are expensive. In addition to the basic pay package, a business needs to provide incentives to achieve sales (typically this is based on commission and/or bonus arrangements) and the equipment to make sales calls (car, travel and subsistence costs, mobile phone etc). It is likely to cost a company to keep one salesperson "on the road". In UK this cost is at least 25 000 f for one salesperson per year²⁸.

2.8.5.1 DESIGNING THE SALES FORCE

Sales representatives do not perform the same kind of selling. In business settings, McMurry has distinguished these six types of sales representatives, ranging from the least to the most creative types of selling²⁹:

1. Deliverer: A salesperson whose major task is the delivery of a product (milk, bread, or fuel).

2. **Order taker:** A salesperson who acts predominantly as an inside order taker (the sales person standing behind the counter) or outside order taker (the soap salesperson calling on the supermarket manager).
3. **Missionary:** A salesperson whose major task is to build goodwill or to educate the actual or potential user, rather than to sell (the medical “detailer” representing an ethical pharmaceutical firm).
4. **Technician:** A salesperson with a high level of technical knowledge (the engineering salesperson who is primarily a consultant to client companies).
5. **Demand creator:** A salesperson who relies on creative methods for selling tangible products (vacuum cleaners or siding) or intangibles (insurance or education).
6. **Solution vendor:** A salesperson whose expertise lies on solving a customer’s problem, often with a system of the company’s goods and services (such as computer and communication system).

Kotler describes six main activities or tasks of salespeople³⁰:

1. **Prospecting** - trying to find new customers.
2. **Communicating** - with existing and potential customers about the product range.
3. **Selling** - contact with the customer, answering questions and trying to close the sale.
4. **Servicing** - providing support and service to the customer in the period up to delivery and also post-sale.
5. **Information gathering** - obtaining information about the market to feedback into the marketing planning process.
6. **Allocating** - in times of product shortage, the sales force may have the power to decide how available stocks are allocated.

As this activities show, salespeople or sales representatives serves as a link between company and its customers and in turn they bring back a lot of information about customers, markets, and competitors to the company.

To fulfill their tasks salespersons should have the necessary skills, abilities and support. The management must be very careful when select these people. And after selecting them, hey should be trained by company. Most sales training takes place on the job or within the company, teaching the standard sequence of the seven steps of the selling process (Figure 2.26):

1. *Prospecting and qualifying.* The salesperson must identify qualified potential customers. The salesperson often has to approach many prospects in order to get a few sales. Therefore, good salespeople would know how to qualify leads, that is screen out poor leads, and identify good leads by looking at their financial ability, volume of business, special needs, and location and growth prospects.
2. *Pre approach.* The salesperson should "do his/her homework" before approaching the prospect. He/she should learn as much as possible about the prospect's company, and the buyers. The salesperson should set call objectives, and decide on the best approach (visit, call, or letter) and right timing.
3. *Approach.* The salesperson needs to get the relationship off to a good start, followed by asking questions about customer's needs or the display of the product (or sample) to attract the buyer's interest.
4. *Presentation and demonstration.* Here, the salesperson presents the product, it's features, and benefits it represents to the buyer. Salespeople can use three styles of sales approach:

canned approach (memorized talk), formula approach (identifies buyer needs, then moves into formula presentation), or need-satisfaction approach (search for customer needs, and then explain how product meets their needs).

5. *Overcoming objections.* The salesperson should seek out, clarify and overcome any objections buyers may have for buying the product.
6. *Closing.* Many salespeople lack confidence, feel guilty about asking for an order, or do not recognize the right moment for closing the sale.
7. *Follow-up.* This final step is a key different between selling the sales-oriented way, and selling the marketing-oriented (or customer-oriented) way. The follow-up ensures customer satisfaction and repeat business. The salesperson should schedule a follow – up call when the initial order is received to check on proper installation, training and servicing. This shows the change in selling approaches to a greater focus on the customer, rather than traditional focus on the sale itself.

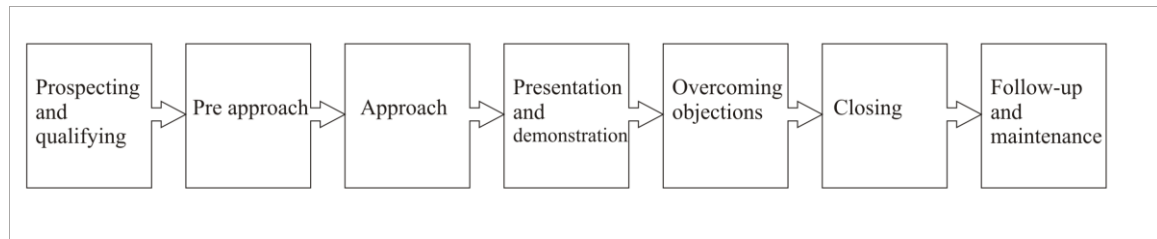

Figure 2.26 Major steps in effective selling³¹

Negotiation – as it seems from above the sale itself is a process, means it consists from some phases and respective activities. Negotiation is one of such the important activities. Salesperson involved in business-to-business deals, needs negotiating skills in order to reach the agreement on price and other terms of sale without hurting company’s profitability. Except price, there are other negotiating issues as well. Among them are contract completion time, quality of goods and services, purchase volume, responsibility for financing, risk taking, promotion, product’s title, and product safety. According to Lee and Dobler³², negotiation is an appropriate procedure for concluding a sale when:

- Many factors bear not only on price, but also on quality and service.
- Business risks cannot be accurately predetermined.
- A long period of time is required to produce the product purchased.
- Production is interrupted often because of numerous change orders.

Before meeting the buyers a salesperson should make a negotiation strategy. A negotiation strategy is a commitment to an overall approach that has a good chance of achieving the negotiator’s objectives. There are many strategies followed by salespersons. Among them, Fisher and Ury propose a strategy of “principled negotiation”³³. In this strategy the parties:

- Actively listen to each other’s viewpoint;
- Focus on their interests rather than on their personal differences or positions;
- Search for options that offer mutual gain; and
- Insist on objective criteria to assess the solution.

In industrial market personal selling has been proved to be more successful promotional method.

2.8.6 PUBLIC RELATIONS

Public relations are part of the promotional mix activities. It is an integral part of the whole marketing process. The Institute of Public Relations in USA defines public relations as follows³⁴:

“The planned and sustained effort to establish and maintain goodwill and mutual understanding between an organization and its publics”. Public relations involve developing good relationships toward all public mediums. The art of good public relations is not only to obtain favorable publicity within the media, but it is also involves being able to handle successfully negative attention³⁵.

But, why the company should take into consideration this promotional activity? Except its current customers, suppliers or intermediaries it must also relate to a large number of interested publics. What is meant by the term *“publics”* above? A public is any group that has an actual or potential interest in or impact on a company’s ability to achieve its objectives³⁶. A business may have many “publics” with which it needs to maintain good relations and build goodwill. Public relations is intended to build good relations with the company's various publics by obtaining favorable publicity, building up a good "corporate image," and handling or heading off unfavorable rumors, stories, and events³⁷. An important role here has the public relations’ spokesman. He has the task to persuade and convince the media of their point of view. An author, Julia Hobsbawn says: *Rule one of good public relations is to tell the truth and rule two is to have credibility as a spokesperson*³⁸.

Public relations offer several unique qualities. It is very believable, like news stories, features, and events seem more real to readers than ads do. Public relations can also reach many prospects who avoid salespeople and advertisements; the message gets to the buyer as "news" rather than as a sales-directed communication. Like advertising, public relations can dramatize a company or product.

In any company, public relations department typically perform five functions³⁹:

- *Press relations* – presenting news and information about the organization in the most positive light.
- *Product publicity* – publicizing specific product.
- *Corporate communication* – promoting, understanding of the organization through internal and external communications.
- *Lobbying* – dealing with legislators and government officials to promote or defeat legislation and regulation
- *Counseling* – advising management about public issues and company positions and image.

2.8.7 SALES PROMOTION

Generally speaking it is hard to describe exactly the term what sales promotion is. One can say that it is a promotional activity which does not fit with other groupings within promotional mix. A good definition of sales promotion would be as follows:

“An activity designed to boost the sales of a product or service. It may include an advertising campaign, increased PR activity, a free-sample campaign, offering free gifts or trading stamps, arranging demonstrations or exhibitions, setting up competitions with attractive

prizes, temporary price reductions, door-to-door calling, telemarketing, and personal letters on other methods”⁴⁰.

While Kotler says: *sales promotion is a key ingredient in many marketing campaigns, and consists of a diverse collection of incentive tools, mostly short term, design to stimulate trial, or quicker or greater purchase, of particular products or services by customers or the trade⁴¹.*

Whereas advertising can be seen by the customers’ viewpoint as a *reason* to buy, sales promotion is an *incentive* to buy.

More than any other element of the promotional mix, sales promotion is about “action”. It is about stimulating customers to buy a product. It is not designed to be informative – as was said above, a role which advertising is much better suited to.

There are many methods used in this promotion technique, such are:

Price promotions - price promotions are also commonly known as” price discounting”

These offer either (1) a discount to the normal selling price of a product, or (2) more of the product at the normal price.

Increased sales gained from price promotions are at the expense of a loss in profit – so these promotions must be used with care. A producer must also guard against the possible negative effect of discounting on a brand’s reputation

Coupons - coupons are another, very versatile, way of offering a discount. Consider the following examples of the use of coupons:

- On a pack to encourage repeat purchase.
- In coupon books sent out in newspapers allowing customers to redeem the coupon at a retailer.
- A cut-out coupon as part of an advert.
- On the back of till receipts.

The key objective with a coupon promotion is to maximize the redemption rate – this is the proportion of customers actually using the coupon.

One problem with coupons is that they may simply encourage customers to buy what they would have bought anyway. Another problem occurs when retailers do not hold sufficient stocks of the promoted product – causing customer disappointment.

Use of coupon promotions is, therefore, often best for new products or perhaps to encourage sales of existing products that are slowing down.

Gift with purchase - the “gift with purchase” is a very common promotional technique. It is also known as a “premium promotion” in that the customer gets something in addition to the main purchase. This type of promotion is widely used for:

- Subscription-based products (e.g. magazines).
- Consumer luxures (e.g. perfumes).

Competitions and prizes – is another popular promotion tool with many variants. Most competition and prize promotions are subject to legal restrictions.

Money refunds - here, a customer receives a money refund after submitting a proof of purchase to the manufacturer. These schemes are often viewed with some suspicion by customers – particularly if the method of obtaining a refund looks unusual or onerous.

Frequent user / loyalty incentives - repeat purchases may be stimulated by frequent user incentives. Perhaps the best examples of this are the many frequent flyer or user schemes used by airlines, train companies, car hire companies etc.

Point-of-sale displays - research into customer buying behavior in retail stores suggests that a significant proportion of purchases results from promotions that customers see in the store. Attractive, informative and well-positioned point-of-sale displays are, therefore, very important part of the sales promotional activity in retail outlets.

2.8.8 DIRECT MARKETING DEFINITION

Direct marketing is a communication between seller and buyer directly without intermediaries, using traditional media (print and broadcast media, catalogs, direct mail, and telephone marketing), fax machines, e-mails, the Internet, and on-line services⁴² (see direct mail, telemarketing, direct on-site, e-commerce in Chapter 8).

Drayton Bird describes direct marketing as “*an advertising activity, which creates and exploits a direct relationship between you and your prospect or customer as an individual*”⁴³.

While Judith Donovan’s definition of direct marketing is that it is “*the science of arresting the human intelligence long enough to take money off it*” (Judith Donovan, 2000)⁴⁴.

According to the Direct Marketing Association (DMA), direct marketing is defined as an interactive marketing system that uses one or more advertising media to affect a measurable response and transaction to any location.

The difference between direct marketing and traditional marketing is really the response that company is trying to get from people. Traditional marketing, through its traditional advertising, is looking to build awareness. Direct marketing is looking for the sale today or in the near future. So the distinctions between advertising agencies and direct marketing agencies are increasingly blurring. While advertising can change people’s attitudes through generating brand desire, direct marketing can change people’s behavior, turning them into active, rather than passive, consumers (Eleanor Tricket, 1998)⁴⁵.

2.8.8.1 GROWTH AND BENEFITS OF DIRECT MARKETING

Direct marketing also enable building of a long-term relationships with the customers (relationship marketing). In building these relationships, some direct marketers send out birthday cards, information materials, or small premiums to select customers in their customer base.

There are many factors that have influenced the growth of direct marketing: higher costs of driving, traffic and parking headaches, lack of time, a shortage of retail sales help, and queues at store’s checkout. All of these and other unmentioned factors have encouraged at-home shopping. Shopping from home is fun, convenient, and hassle-free; it saves time gives more information.

Electronic communication technology is showing explosive growth, with internet traffic doubling every 100 days⁴⁶. Millions of businesses Web sites are already open around the

world. *Electronic business* is the general term for buyers and sellers using electronic means to research, communicate, and potentially transact with one other. *Electronic markets* are sponsored Web sites that⁴⁷:

- Describe product and services offered by sellers;
- Allow buyers to search for information, identify what they need or want, and place orders using optional selling methods (credit cards, or other methods!);

After these activities, the product is then delivered physically (to the customer's office or residence) or electronically (software and music can be downloaded to a customer's computer).

The internet can give the possibilities of promoting company's products and services nationally and internationally. So promotion in the internet is very cheap and very effective, because the money can be saved by not having to produce glossy brochures, not having to undertake expensive mailings, and not having to have a presence on the high streets⁴⁸.

Customer database and direct marketing – aiming to shift from mass marketing to highly targeted, one-to-one marketing, marketers are using information technology to build customer's databases (Table 2.11). A *customer database* is an organized collection of comprehensive data about individual customers or prospects that is current, accessible, and actionable for such marketing purposes as lead generation, lead qualification, sale of product or service, or maintenance of customer relationships⁴⁹.

While *database marketing* is the process of building, maintaining, and using customer databases and other databases (products, suppliers, resellers) for the purpose of contacting and transacting.

With customer database the company can achieve a more target precision than it can with mass marketing. Company use databases in four ways:

To identify prospects: bases on the information in the database the company can sort and identify the best prospects and then contact them by mail, phone, e-mail, or personal sale and try to convert them into customers.

To decide which customers should receive a particular offer: company set up criteria describing the ideal target customer for an offer, and then searches the database to match those closely resembling the ideal type?

To deepen customer loyalty: companies can build interest and enthusiasm by remembering customer preferences and by sending gifts, coupons, and special information.

To reactivate customer purchase: companies can use automatic mailing programs to send customers birthday, holiday shopping reminders, off-season promotions, etc.

Table 2-11 Mass marketing versus One-to-one marketing⁵⁰

Mass Marketing	One-to-one Marketing
Average customer	Individual customer
Average anonymity	Customer profile
Standard product	Customized market offering
Mass production	Customized production
Mass distribution	Individualized distribution
Mass advertising	Individualized message
Mass promotion	Individualized incentives
One-way message	Two-way messages
Economies of scale	Economies of scope
Share of market	Share of customer
All customers	Profitable customers
Customer attraction	Customer retention

Major channels for direct marketing – direct marketers use a number of channels to reach their prospects and customers. These include⁵¹:

- *Face-to-face selling*: company hires manufacturer’s representatives and agents to carry out the direct selling task.
- *Direct mail*: involve sending an offer, announcement, reminder, or other item to a person at a particular address.
- *Catalog marketing*: occurs when companies mail product catalogs (specialty consumer catalogs, or business catalogs in print, on CD, or on-line).
- *Telemarketing*: describes the use of telephone operators to attract new customers, to contact current customers, etc.

2.8.9 HOW TO ESTABLISH A CUSTOMER CARE CULTURE

Customers are vital to the company's success. If they are treated badly than they will never come back to. Perhaps you have experienced this. You are in a restaurant, have eaten and didn't enjoy your meals. Your plate is half-eaten food. Then comes the waitress to remove your plate, sees that your plate is half-eaten food and mechanically ask if you have enjoyed the meal. You, of course, can't say to her neither yes nor no. And you noticed that she asked because she's been told to. And you vow never again to turn in that restaurant. Even more, you will aware all of your friends how awful the restaurant is. Already is obvious what a bad customer care is for customer: a bad experience. This is not enough, it is bad for the business too, because dissatisfied customer will never come back⁵².

Now before saying that your business is not like that described in the previous example, ask your self if that 100 per cent of your customer are happy with you, 100 per cent of the time? Put hand on the heart, because it's better for you to be realistic on analyzing your company's customer care, fix its weaknesses and improve what can be improved as soon as possible, otherwise it can happen to become late. Now after it has been made clear of what bad customer care does, let's have a look on what do you gain if good customer care is applying. Here are some of the reasons why should began to tackle customer care.

2.8.9.1 FIVE REASONS WHY YOU SHOULD CARE

According to Ali⁵³, there are five reasons why the marketers should to take care for customers:

1. It is cheaper to keep a customer than to win a new one. It is sad from some experts that it can cost between 3 and 30 times as much to win a new customer as to keep an old one.
2. Satisfied customer repeat sales, come again back to you.
3. Satisfied customer adds to you new business by making recommendations to their friends for you.
4. Good customer care helps you to differentiate yourself from the competition.
5. Good customer care is good for your reputation. On the other hand bad customer care will damage company's reputation and company's profit too.

2.8.9.2 A FORMULA FOR SUCCESS

So good customer care makes sense on making business and it affects the business. But, how much it affects, just below is a formula to calculate what each customer is worth to you (Table 2-12).

Use these figures (A, B, C, D) to calculate the sums below:

$A \times B = F$, this gives sales per customer per year;

$F \times C = G$, gives sales per customer over lifetime (years a customer buy from you);

$G \times D = I$, gives gross sales from recommendations (referrals);

$G + I = \text{€}$, gives Grand total;

This Grand Total is the total value of a satisfied customer. Perhaps it looks a little complicated calculation working like this, but let take a concrete example and demonstrate how simple this formula is. Suppose you run a boutique:

- Your average sale is 20.5 € (A)
- Each regular customer visits you five times a year (B)
- Your customers continue buying from you for around 6 years (C)
- Each recommends three of their friends to you (D)

Here is how to calculate the value of one customer:

- Sales per customer per year = $A \times B$ (ex. $20.5 \text{ €} \times 5$) = $102.5 \text{ €} = F$
- Sales per customer over lifetime = $F \times C$ (ex. $102.5 \text{ €} \times 6$) = $615 \text{ €} = G$
- Gross sales from recommendations = $G \times D$ (ex. $615 \text{ €} \times 3$) = $1845 \text{ €} = I$
- Total value of satisfied customer = $G + I = 615 \text{ €} + 1845 \text{ €} = 2460 \text{ €}$.

Table 2-12 Calculation of worth of a customer⁵⁴

1. Calculate your average sale (annual sales in € divided by number of transactions). Write the answer on the right side under A:	A =
2. Now make a guess at the number of sales you get each year from the same regular customer (How many times per year visits and buy that customer). Write the answer on the right side under B:	B =
3. Multiply B by the number of years a customer buy from you on average. Write the answer on the right side under C:	C =
4. Now think about the number of recommendations your existing customers make to their friends to buy from you. Write the answer on the right side under D:	D =

So next time do not feel irritated with the customer, he did not buy from you only 20.5 € but effectively 2460 €. Why? Because, his/her recommendations have added value to you, by selling a product to three of his/her friends or whoever they have recommended to you. That is why number of buyers is 1+3 which gives a total of real four. But, have in mind, that the real cost of a lost customer is much higher. The recommendations that they will make to their

friends against you, for sure, will be much more than those in favor of you. So do your best you can to keep your customer happy.

So far, lots of discussions took place mostly about that why one should take customers care seriously. Let's have a look if the opposite happens. Let's assume that you visit a shop and the assistant ignores your need for help telling his/her fellow assistant about a recent night out. You will create a bad impression for that shop and not just for the assistant. Your bad impression will spread out to the other stores near it. A judgment regarding one staff member will be also extended to the entire staff. And this happens in our case with "assistant – shop" and with "shop – other shops" in the chain. So every member of company has his/her significance at creating of a good or bad impression on customers. *The companies do not exist as entities on their own right, but they are made of staff and judged based on skills and attitude of the staff*⁵⁵.

2.8.9.3 STARTING WITH STAFF

It depends to your staff to deliver excellent customer care. But, don't expect them to do this by their instinct. You have to show them how to offer good customer care. In most cases new staff working in shops first began training in handling money and then people. Not good approach, isn't it? If they don't now to handle with people they won't be handling much money. Staff that needs to use a computer is given computer training, those who interview people are given selection training. And staff that has to handle with people shouldn't need to make an exception. Means they need to be trained on how to handle with people. Staff needs to be trained in the importance of customer care and in customer care skills⁵⁶.

Furthermore each member of staff needs to be trained. Let's argue this with an example. Let's take cleaners in the hospitals, which have a great deal of contact with public. Lost visitors ask them during all the day for different directions, interrupting and disturbing them in cleaning the corridors. They regard visitor's questions as unwelcome. They don't have attended any customer care training course to, so it's not their fault. Bellow will be given an own experience of mine.

True story

I went in a restaurant in Prishtina for lunch. The waiter came to me and asked me: "what do you want eat sir, please?", and I really did not decide yet and answered to him: "I really don't know". He looked to my face and astonished answered to me: "If you don't know how can I know". He was not willing to help me in my decision on what to lunch. He might to say: "OK sir, can I help you to choose", or something like that, and not cancel the act of selling the restaurant's products.

Reference:

- ¹ Kotler P., Framework for Marketing Management, 2001
- ² Rexha N., and Reshidi N., Basics of Marketing, 2002
- ³ Morden A.R., Elements of Marketing, 1993
- ⁴ Morden A.R., Elements of Marketing, 1993
- ⁵ Kotler P., Framework for Marketing Management, 2001
- ⁶ Kotler P., Framework for Marketing Management, 2001
- ⁷ Kotler P., Framework for Marketing Management, 2001
- ⁸ Kotler P., Framework for Marketing Management, 2001
- ⁹ Adopted from: www.wikipedia.org
- ¹⁰ Kotler P., Framework for Marketing Management, 2001
- ¹¹ Morden A.R., Elements of Marketing, 1993
- ¹² Billes G.B., Marketing , 1994
- ¹³ Rexha N., and Reshidi N., Basics of Marketing, 2002
- ¹⁴ Kotler P., Framework for Marketing Management, 2001
- ¹⁵ Kotler P., Framework for Marketing Management, 2001
- ¹⁶ Morden A.R., Elements of Marketing, 1993
- ¹⁷ Adopted from: www.wikipedia.org
- ¹⁸ Morden A.R., Elements of Marketing, 1993
- ¹⁹ Kotler P., Framework for Marketing Management, 2001
- ²⁰ Rexha N., and Reshidi N., Basics of Marketing, 2002
- ²¹ Neidle A., How to get into Advertising, 2001
- ²² Salzman Andrew, Siebel Systems, 2001
- ²³ Neidle A., How to get into Advertising, 2002
- ²⁴ Adopted from: www.wikipedia.org
- ²⁵ Adopted from: www.tutor2u.net
- ²⁶ Adopted from: www.usoe.k12.ut.us
- ²⁷ Adopted from: www.tutor2u.net
- ²⁸ Morden A.R., Elements of Marketing, 1993
- ²⁹ Kotler P., Framework for Marketing Management, 2001
- ³⁰ Adopted from: www.tutor2u.net
- ³¹ Kotler P., Framework for Marketing Management, 2001
- ³² Kotler P., Framework for Marketing Management, 2001
- ³³ Kotler P., Framework for Marketing Management, 2001
- ³⁴ Adopted from: www.tutor2u.net
- ³⁵ Adopted from: www.learnmarketing.net
- ³⁶ Kotler P., Framework for Marketing Management, 2001
- ³⁷ Adopted from: www.tolearn.net
- ³⁸ Neidle A., How to get into Advertising, 2002
- ³⁹ Kotler P., Framework for Marketing Management, 2001
- ⁴⁰ Adopted from: www.tutor2u.net
- ⁴¹ Kotler P., Framework for Marketing Management, 2001
- ⁴² Neidle A., How to get into Advertising, 2002
- ⁴³ Roddy Mullin, Direct Marketing, 2000
- ⁴⁴ Roddy Mullin, Direct Marketing, 2000
- ⁴⁵ Neidle A., How to get into Advertising, 2002
- ⁴⁶ Kotler P., Framework for Marketing Management, 2001
- ⁴⁷ Kotler P., Framework for Marketing Management, 2001
- ⁴⁸ Ali M., Practical Marketing and PR for the Small Business, 1998
- ⁴⁹ Ali M., Practical Marketing and PR for the Small Business, 1998
- ⁵⁰ Kotler P., Framework for Marketing Management, 2001
- ⁵¹ Kotler P., Framework for Marketing Management, 2001
- ⁵² Ali M., Practical Marketing and PR for the Small Business, 1998
- ⁵³ Morden A.R., Elements of Marketing, 1993
- ⁵⁴ Ali M., Practical Marketing and PR for the Small Business, 1998
- ⁵⁵ M., Practical Marketing and PR for the Small Business, 1998
- ⁵⁶ Morden A.R., Elements of Marketing, 1993

3 PROBLEM RESOLUTION

3.1 PROBLEM DEFINITION

As it was cited at the very beginning of this thesis, the orientation of Kosova toward free and open market economy has resulted to the creation of many small and medium sized companies. Since these companies are in a very beginning of their business and in the same time are facing with a very high competition among each other, they need to be familiar with some basic concepts about this new business environment (marketing concept).

A lot of these new business techniques Kosova's marketers are embracing by daily experience, but some theoretic concepts are very useful to them. Because it is well known that some amount of budget should be allocated to these marketing activities. Hence marketing concept is supported on market analyzing and thus on the appropriate methods and budget used.

3.1.1 IDENTIFY THE OBJECTIVES

The objective is to give in a very explicit way the basic concepts, to display some arguments of the position and circumstances of marketing concepts in Kosova's companies by searching that have been done and to offer the different alternative solutions of different aspects taken into account.

By working in this way, it will be tried to enforce Kosova's marketers to analyze their situation and to find the better offered solutions against their competitors. Based on the marketing concept theoretical knowledge explained, hereafter it will be displayed some collected data which can be matched in Kosova's market.

3.1.2 COLLECTED DATA

Whilst marketing concept usually suggests that successful business will be "marketing orientated", it is the case in the real world not all businesses subscribe to the marketing concept. This is the case in Kosova, too. Means, the marketers intentionally have decided to be oriented on other market systems (have a look at [WHAT IS MARKETING AND MARKETING CONCEPT](#)), as:

- Selling orientation - Selling approach to business can be seen in Kosova in the market of Car Assurance companies, airline companies, etc.
- Production orientation - In Kosova's case regarding that there is no big market, especially the small and medium company's business policies should concentrated better in marketing concept then in production alternative. Otherwise it can be a risk of impossibility to sell their product or services.
- Product orientation- Very beautiful restaurants can mentioned here as cases in Kosova's market. Because these restaurant offer very high food quality but having in mind the economical situation here their management forget that they can sell to only a small number of potential buyers.

Regarding economic policies Kosova is one of the most economically undeveloped countries in Europe. Consumers in Kosova have experienced significant decline in living standard over the last two decades. Kosova has a totally broken industry, so it couldn't remain competitive and capable of winning businesses in highly sophisticated and technologically advanced markets.

Considering the economy of Kosova among many economical analyses I have chosen that of Dale Pfeiffer, (USAID/Kosova, Mission ex-Director) in his remarks entitled "The economy - perspectives and problems". He pointed out those challenges facing the economic development of Kosova fit into 12 problem areas. There is a brief quote below according to him regarding to these areas¹:"

1. Poor transportation infrastructure – meaning roads, rail and air, all of which must be improved to overcome isolated geographic position.
2. Lack of statistical data. It's needed to do business, to propose business, to analyze the economy and make good decisions.
3. A poor land market. The lack of clear title and uncertainties on ownership hurts business and business growth.
4. An underdeveloped legal system. It is improving. Beware of the opportunities for corruption that come with over-regulation. Citizens need to take responsibility for this - if individuals don't stand up, report, fight, or complain about corruption - it won't change. This requires courage.
5. Brain drain and lack of skilled labor and the labor climate. Not enough is being done to address the educational requirements Kosova needs to achieve to compete in Europe. The share of people attending college is the lowest in Europe at 15% - this is too low, and many of the more educated Kosovars are not in Kosova. It needs a sophisticated workforce with managerial and technical skills equal to any in Europe if this is to be a prosperous place. And the wage expectations, prices for goods and services, real estate and labor are the highest in the region. Certainly wage expectations have been driven up by the international employers here. If Kosova is to attract foreign investment, the prospect of low-wage and other factors will be critical.
6. Poorly maintained energy and water infrastructure. An unstable water supply and power shortages hurt business, and hurt business development. Poor energy is perhaps the major obstacle blocking economic development right now.
7. A lack of favorable, stable foreign trade relations with neighbors and with the EU. Kosova is land-locked. It must cross neighboring space. This can only be compensated for if Kosova's trade arrangements with its neighbors are based on well-written and routinely observed trade agreements. Kosova is market is too small to attract significant foreign investment on its own. Investors must have the possibility of easily exporting to countries in the region and the EU.
8. Little private investment. Private investment here is primarily in residential construction. Further privatization will increase some private investment, but Kosovars need investing in their own businesses. Kosova needs to have productive enterprises in order to replace imports, begin to earn profits from exports, and to create jobs. The focus now is on quick profits from trade, and trade creates relatively few jobs.

9. Lack of city planning or zoning. This inhibits rapid and rational real estate development, very important to business development.
10. Underutilization of agricultural resources. Kosova could do much more to satisfy its internal market and expand regional markets, as well as more processing of agricultural goods. There are still impediments to privatizing the agricultural sector, between issues of land ownership and ownership of agribusiness processors. Additionally, efficient exportation of agricultural goods requires trade agreements, mentioned earlier, and transportation infrastructure and facilities.
11. Credit and financing. This is a problem. Underdeveloped credit markets - even the lack of credit cards - results in high costs of borrowing.
12. Last 'problem facing Kosova's economy' is political uncertainty. Many people point to this as the number one problem for Kosova. Each political status should satisfy foreign investors and should satisfy domestic investors as well. “

Kosova's Trade Regime - Concerning foreign economic relations already have been established some other regulations, such are:

- New Customs Code for Kosova- is based on the EU custom code and fully WCO (World Custom Organization) compliant. This code regulates the use of main trade facilitating instruments such as: bonded warehousing, inward processing relief, processing under customs control, transit, temporary admission, binding information and guarantees².
- among these more significant are Trade with European Union and Free Trade Agreements (FTA), which are the main instrument of further trade liberalization, lead by the intention to integrate Kosova into the network of FTAs initiated under the Stability Pact for South Europe. Kosova has concluded Free Trade Agreement with Albania in 2003, too.
- In addition, On 19 December 2006, Kosova Joined Enlarged Central European Free Trade Agreement (CEFTA)³.

Environmental factors - When was discussed about marketing system earlier, it was said that it has its environmental factors as well. One of them is financial community which helps to create the favorable business environment for companies. In Kosova there are Kosova Chamber of Commerce and Alliance of Kosovar Bussines.

The mission of Alliance of Kosovar Business is to unify business associations and hence to effort in economical politics and to develop private sector (source: www.akb-ks.org)⁴.

While Kosova Chamber of Commerce (source: www.odaekonomike.org) is an independent trade and business association of manufacturing, trade and service companies, banks, insurance companies, research institutes of all kinds of ownership, that became members of the chamber on basis of the Law on Kosova Chamber of Commerce. Its activities include⁵:

- Improvement of business operations.
- Stimulation of research and development.
- Business information.
- Organization activities in the field of economic relations with foreign countries
- Improvement of business operations.
- Improvement of business operations in the field of private entrepreneurship
- Representation of interests of its members both at Kosova authorities in the field of economic system, development and economic policy.

- Encouraging of good business practices and business morality • Other activities in the interest of its members.

Another environmental factor is **political factor**, which (as was said) had a huge influence on regulation of businesses, so it had a direct impact on the marketing system. The political environment in Kosovo is mainly stable. Although the final political status is solved, (Kosovo has gained Independence by 17 of February 2010), the government has a lot more to do to attract foreign investors.

Market segmentation procedure - Based on the gathered facts made public in Kosovo, the companies here have not begun to conduct any market survey activity aiming to segment their market. That's why the marketers of companies in Kosovo should take into account the market segmentation advances and benefits. In order to have effective and powerful market segmentation some research costs should be put apart, which in turn would give the company much more information concerning situation in the market and would increase chances to enhance the margins.

Below are shown some market segmentations cases that have been met in Kosovo market. These segmentations belong to demographic, psychographic and behavioral segmentation.

Demographic segmentations met have been based on:

- Age - Young population in Kosovo constitutes seventy percent of its overall population. As far as birthrate is concerned, it is lower compared to previous years, however it is still stable compared to European countries. These two variables are exploited very well by boutiques, cafeterias and marketers of diapers, marketers of toothpaste for children and adults and toys with many age-based segments. Ex. Raiffeisen bank in Kosovo, recently has offered a special offer for people between 16 and 35 year old. If viewed in general, this variable is not often used by companies here.
- Gender- Hence in Kosovo nowadays the number of women receiving driving licenses is increasing (this case has rarely occurred prior to five years); the car marketers can exploit this fact to provide the market with cars designed for women.
- Income- Since the average income in Kosovo is very low (about 250 €) that's why we see recently established shops offering "everything 2 €" or "everything 1 €". This can be a good solution for social classes that have low incomes.

While psychographic segmentations met have been based on:

- Personality- There is an airline company in Kosovo, which has depicted the Albanian flag in its airplane wings. This fact has had an impact on personality of many Albanians, and as a result they fly with pleasure with this company despite the services that offer.
- Lifestyle- There is some hatters in Kosovo, who produce and sell Albanian traditional white hats. Or Indian tea, which is the predominant tea in Kosovo, and one, would run a very good business by selling this kind of product. However, according to Kotler⁶, lifestyle segmentation does not always work. Nestle introduced a special brand of decaffeinated coffee for "sleepless people", and it failed, presumably because people saw no need for such a specialized product.
- Values- If marketing managers of companies in Kosovo tend to use values as variables on market segmentation, they should take into consideration especially groups of intimate people predominant here in Kosovo.

And finally, behavioral segmentations cases were based on:

- Occasions- in Kosova there are private buses, which serve only pupils of any private schools opened recently. A company can also consider critical life events to see whether they are accompanied by certain needs. The kind of analysis has led to service providers such as marriage, employment, and bereavement counselors. Another example in Kosova is a recently opened company which helps people to find partners for marriage.

Product policy – companies in Kosova have made some progress in using branding and packaging as only elements of creating their product policies.

Most of the small companies serve as retailers. It is very useful tool for them to create their own label of brand, aiming to provide their customers with more quality image. Therefore, they can be viewed as equal to or better than manufacturers' brands. Regarding brand name decision there are companies in Kosova like: "Five Brothers" who reflect an image of the strong company, or the name like "Interemineks"- reflects something modern, but also automobile mechanic who named his working place "Caramboll" – that in English means Carom, not known what he wanted to say!

Companies as "Fruti" or "Devolli" in Kosova, have a very good packaging of their products. Another factor that should be taken into consideration by all other companies in the country is the ecological component of their products. Because, based on actual environmental circumstances there are great chances that their packages have to be exposed for a long time in the life environment of human beings and chemical decompositions may occur.

Price – Concerning pricing strategies marketers in Kosova mainly have pursued the method of Maximum Current Profit, Premium Price-quality Strategy, Maximum Market Share, Product Quality Leadership and Psychological Pricing (have a look at chapter [SETTING THE PRICE](#)).

Maximum Current Profit ignores long term effects of this pricing objective. Several football halls have been built in various places in Kosova, and a lot of money have been invested on them (about 40 000 € per hall!). The price to play on these halls is 25 € to 30 € per hour. Obviously, it is too expensive. These halls are approximately far away from each other, that's why they are very frequented by interested people, who don't have other choices because of lack of football areas. Having in mind the investments that have been done, these companies have been oriented to maximum current profit and thus cover their investments as soon as possible.

As an example of Premium Price-quality strategy I saw a coat of Versace in a boutique in Prishtina which cost 1300 euro. This boutique indeed has competitive advantage compared to other ones.

As a strategy of Maximum Market Share several big supermarkets have been open in Kosova, oriented to high volume selling and consequently they won larger markets due to their average lower prices in comparison with other small supermarkets regarding commodities they offer.

On Product Quality Leadership some Slovenian companies have find their distribution channels here in Kosova and charge high prices for their washers what most other washers cost-because, as its ads point out, the appliances use less water and electricity and prolong the life of clothing by being less abrasive. Here, the strategy of these Slovenian companies is to encourage buyers to trade up to new models before their existing appliances wear out.

Finally as Psychological Pricing, there are cases used very much in Kosova as well. After the war the Kosova's market somehow got opened for importing of many new products. The qualities of these products in most cases were and still remain unknown for customers. The users perceive these products in an irrational way, based on their prices.

Distribution channel – since in Kosova consumer market is much more developed than industrial market is, wholesalers and retailers are widely used as types of intermediaries in distribution channels. But, as another method of selling, Direct (on site) selling is very common in Kosova. This method of selling is widely used because the target customers are mainly within the local area. This method is very useful for small businesses, and as it is well known that in Kosova there are a lot of them.

Other kind of selling methods have begun to be used in by marketers in Kosova as well, such are Direct Mail, Telemarketing and E-commerce.

Direct Mail has begun to be used as well. There is a supermarket called MAXI here in Prishtina, which is using this method of selling. This supermarket uses part time employees, who were shown everywhere in the city, even into many buildings spreading their catalogues out of the flat's doors.

As a Telemarketing Selling telephone calls are used in those rear cases of this selling method. Anyway, there are some few examples of applying this selling method in Kosova.

Regarding E-commerce (Internet) companies in Kosova are purely Internet orientated in selling their services and products completely via their web site. Accordingly, the role of Internet in their businesses is increasing more and more, firstly by using e-mail and then web sites. Based on some old data from a sample of 90 registered businesses carried out by Statistical Office of Kosova , 47 of the companies have an e-mail address or use it (means 52 % of this sample), and 43 of them do not have an e-mail address (48 % do not have e-mail addresses).

While based on the data presented by a web site <http://www.kosovabiz.com/>, from a sample of 90 companies, 50 % of them have already their web sites.

In the future, the role of the Internet as a possible distribution channel will be increased.

Promotion policy – among five promotional mix tools marketers here uses most widely the advertisement and personal selling.

As an advertising media are used Television, radio and newspapers. Exceptionally TV as a medium is used very much by many companies in Kosova. Football games, Modern Family serial, Lottery shows are known as much for their commercial advertisements. On **Error! Reference source not found.**, there are indicated common prices for advertising spots on Kosova Public Radio Television – RTK of Kosova. Whereas, on **Error! Reference source not found.**, prices for advertisement during special programs of RTK. And, on **Error! Reference source not found.** are shown prices of placing products into programs of RTK.

Table 3-1 Common prices for advertising spots in RTK ⁷

Period	Description	Price/sec
7:00 – 17:00	Morning Program	€ 4.00
17:00 – 19:20		€ 4.00
19:20	Before Central Edition of News	€ 10.00
19:45	In the middle of CE of News and Weather forecasting	€ 10.00
20:00 – 20:30	After Central Edition of News	€ 9.00
20:30 – 22:00		€ 8.00
22:00 – 23:00		€ 7.00
23:00 – 23:50		€ 6.00
23:50	Before BLIC News	€ 7.00
00:00 – 07:00	After 24:00	€ 2.00

Table 3-2 Prices of RTK during special programs of RTK ⁸

Description	Price/ sec
Local Serial "Modern Family"	€ 30.00
Humoristic program "Quza", "Show Meselation"	€ 15.00
Transmitting of international sport's games	€ 5.00
Transmitting of local sport's games	€ 8.00

Table 3-3 Prices of placing products into programs of RTK ⁹

Description	Price per product/episode
Local Serial "Modern Family"	€ 1,000.00
Humoristic program "Quza", "Show Meselation"	€ 200.00
Morning Program	€ 50.00

New media – these media are not used here, but it was taken as an example of how they are used in USA. According to Dave Katz¹⁰, the characteristic differences between new media and traditional media are that the new media are those forms of advertising media which are interactive. Although the term is usually applied solely to online advertising (internet, websites, emails), he feels that the term applies equally to digital TV and mobile platforms (e.g. WAP). The largest and fastest interactive media are the internet and digital TV. In the Figure 3.1 The new networks, is shown the use of media in USA. From the graph seems that the usage of new media as cable and satellite TV (see curve 2), is growing up each year. Also the usage of internet for buying purposes is growing dramatically (see curve 4).

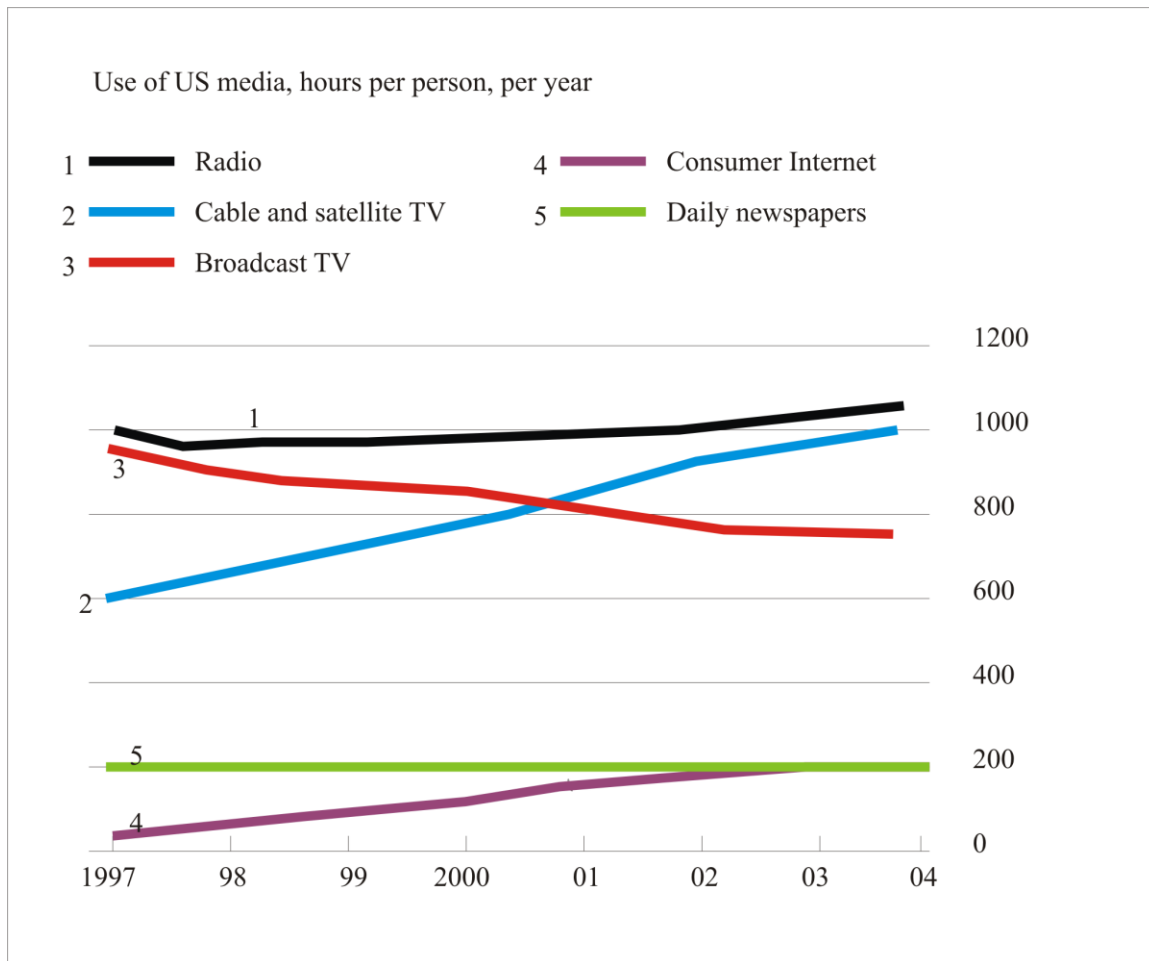

Figure 3.1 The new networks¹¹

Regarding Personal selling's main disadvantages of using personal selling is cost. In a big companies in Kosova this cost is around 3 000 euro per month (in this cost was included salary, travel expenses inside Kosova and food!). All of these activities of using personal selling should be performed by sales representatives.

3.2 PROPOSALS

Based on collected data from Kosova's market it is obvious that marketers in Kosova have a lot to do being marketing oriented and to use the tools of marketing concept. Anyway it was told that in many cases they use other market systems. Concerning selling, production and product business orientation alternatives each of three alternative business orientation have common sense. Products must be made to a proper specification. Also the potential customer will not make up his or her mind without some sales pressure, although some customers dislike "the hard sell". But any one of these orientations is inadequate. It is highly risky to invest in manufacturing plant and design production capability before making a market research and finding out the market demands. Whereas considering business orientation alternative, in the Kosova many investors having no knowledge of where to invest their money elsewhere have invested in fuel pumps although the market is fed up with this service. As a consequence, many of them have failed from the beginning of their business activity. A

marketing-oriented company management, would take all these factors into account, and would manage its affairs in a more systematic way. Accordingly, it would put the marketing concept into practice.

When a company decides to be a marketing oriented one, as it was said earlier first thing that should do is to create its marketing department. There are a lot of inter-related activities between the management and staff of company's marketing department. Let's assume a company that produce and sells a range of products, such as different kinds of drinks. The more specific responsibilities of marketing department in this case might be¹²:

- **Identifying and forecasting market demands and opportunities:** it should research the needs and wants of different market segments. This information can be getting out by making a Market Research. At the same time the marketing department needs to be aware of technological developments taking place outside the company, and it should suggest new product developments.

For example here in Kosova, after processing a Market research data, the marketing department has more information of which kinds of drinks are drank by different types of customers and based on this the marketing it by presenting the relevant arguments can suggest to the management launching of new kind of drink.

- **Managing products:** the marketing function is responsible for forecasting and managing the rate of supply and distribution of the company's existing products.
- **Choosing the channels of distribution:** a producer of drinks can't deliver its products directly to all customers for sure. That's why it is responsibility of the marketing department to find the distributors to stock and sell company's products on its behalf. Thus by marketing department should be selected those wholesalers and retailers who have the most interest on selling its products to those customers who have decided to buy such drinks amongst of wide choice of competitor's drinks. Thus these wholesalers and retailers as a "channel of distribution" are a very important factor of the process of selling. Because, mostly they are separate companies and final sale of products is in their hands, not on the hands of producer. Hence, they must be encouraged and supported on the process of selling by the producer. It is obvious that company's success is depended from their one and they must know perfectly the features of the products as much as producer knows.
- **Promoting the products and services:** the marketing function is also in communicating to target market customers by promoting the products. The benefits of customers to be obtained by purchasing the product should be made clear. Thus by promoting the products the interest of target customers will be increased, hence will be increased the interest of new potential customers. Promotional process aim to encourage and persuade customers to have consideration for products, reassures that by buying products they have made the right decision and support wholesalers and retailers in selling the products too. By promoting and advertising products, the company stimulates the potential buyer to become interested for purchasing and hereafter it will be the retail salesperson's job to change this customer's volition to decision to purchase, thus the act of selling is made.
- **Setting prices:** the marketing department should be closely involved in setting market prices, terms of supply and payment conditions. Other departments should be also involved in this activity, including financial department, etc. The marketing responsibility is to quote prices of products for both distributors and to the final customer. Thus the customer must perceive that the price that he has pay for the product is reasonable

competitive in comparison with the prices of other producers of drinks. In the same time the conditions of supply and terms of payments should be established with the distributors of company's products. A reasonable period should be determined for the payments that distributors should pay to supplier (company!). Otherwise, a huge amount of company's working capital should remain on the hands of its debtors or to the businesses that have taken delivery of products but have not yet paid for them.

- **Planning the marketing activities:** any business activity must have its planning. Planning is an essential part of the marketing activities also. Marketing planning must cover, in detail, items such as annual sales forecasting, annual amount of expenditures on promotion activities, the rate that customer are willing to pay for goods received, time scale of new product development and launching and the expenditures of marketing activities as a whole. Some of the marketing activities are summarized in Figure 3.2.

Thus marketing system has been created in the company. As explained, each system has its environment. Between other environmental factors, marketers should have a lot of consideration regarding culture of their market (clients). Since language as a part of the culture plays a significant role in the marketing system, the marketer should use the right language if he is to achieve an effective communication in the market.

This last sentence is very important to keep in mind the marketers in Kosova, because daily they have to be in the contact with internationals. I saw an old farmer who did learn elementary words and numbers 1 to 10 in English during his daily goods sales.

Marketing mix tools - Given that all of marketing mix factors may change very fast in Kosova, especially environmental forces (having in mind the legal system, which is being established day by day and political factor that may change!) the marketing management of companies should take this seriously into account in designing the marketing mix. Their initial mix should have possibilities of fast changing and adapting to new circumstances that can happen on.

These opportunities should be taken into account by marketers in Kosova, when they use **market segmentation**. They should bear in mind that among segment members can be any member with special needs and wishes. Therefore, a company should fulfill their requirements aiming to keep customers. They would have a double benefit out of this, because on the one hand they keep a customer, and on the other hand some extra sales are realized. Marketers in Kosova should examine carefully segmentation pattern possibility as well (have a look at [PATTERNS OF MARKET SEGMENTATION](#)). They must understand these customer preferences in order to better positioning their brand in the target market segment. They also should take into consideration the competitive implications.

After all analyses and market segmentation have been made by company, it is necessary to review whether all market segments are still useful. This can prevent any predefined expenditure related to any market segment. Philip Kotler analyzed this issue and concluded that in order to be useful and effective, market segments must be¹³:

- Measurable: the size, purchasing power, and characteristics of the segment can be measured.
- Substantial: the segments are large and profitable enough to serve. A segment should be the largest possible homogeneous group worth going after with a tailored marketing program.
- Accessible: the segments can be effectively reached and served.

- Differentiable: the segments are conceptually distinguishable and respond differently to different marketing mixes. If two segments respond identically to a particular offer, they do not constitute separate segments.
- Actionable: effective programs can be formulated for attracting and serving the segments.

Product life cycle - The companies in Kosova should take into consideration this model, because it can help them recognize the stage of their products. Thus, the management can better create appropriate marketing mix elements at different stages. Furthermore, expenditures may be adapted in accordance with the stage of life cycle of a product. Promotional activities can be adopted also in due manner, according to the given stage of the product.

Brand name decision - based on economical environment in Kosova, for the retailers it might be better if they use the method known as Separate Family Names for all Products. This method has a promotional advantage upon which awareness and reputation can be built for the whole range of product or services carrying the same brand. Based on this method, if the company decides to launch a new product or service, then this new product will be easy accepted by customer, because it belongs to the range of known branded products. Some computer companies are exploiting power that a brand has, because they use a licensed brand of international large companies as IBM, HP, acting as local distributors. Another company in Kosova, which is among main distributors in Kosova for groceries, named “ELKOS” uses “its own private label” brand for some of their products.

Another trick on giving names to brands, aiming to attract attention of potential customers is to use the uncommon letters of language. In Albanian language such a letters may be X, Y, etc. Hence one might rarely come across these letters, and marketing management of companies may try to use these letters to attract attention of potential buyers.

Regarding Pricing strategy, price discounts in Kosova already have began to be applied. As an example, in an auto shop, the price for 1 liter of oil was 4 € while if you take 4 liter the price was only 13 €. But discounting never should be used just because other companies do. It should be used only if it is well known what it is going to be believed and achieved by so doing. If company must discount, it should use it creatively.

- Don't just offer 20 per cent off; combine it with a time limit to force the sale.
- Use discount to sell more. For example, offer the discount only if a sale is for more than certain amount, or only if the customer buys two.
- Rather than offer cash off, give away something extra free. For example, offer the customer something that has a high perceived value, but which actually costs to the company very little.

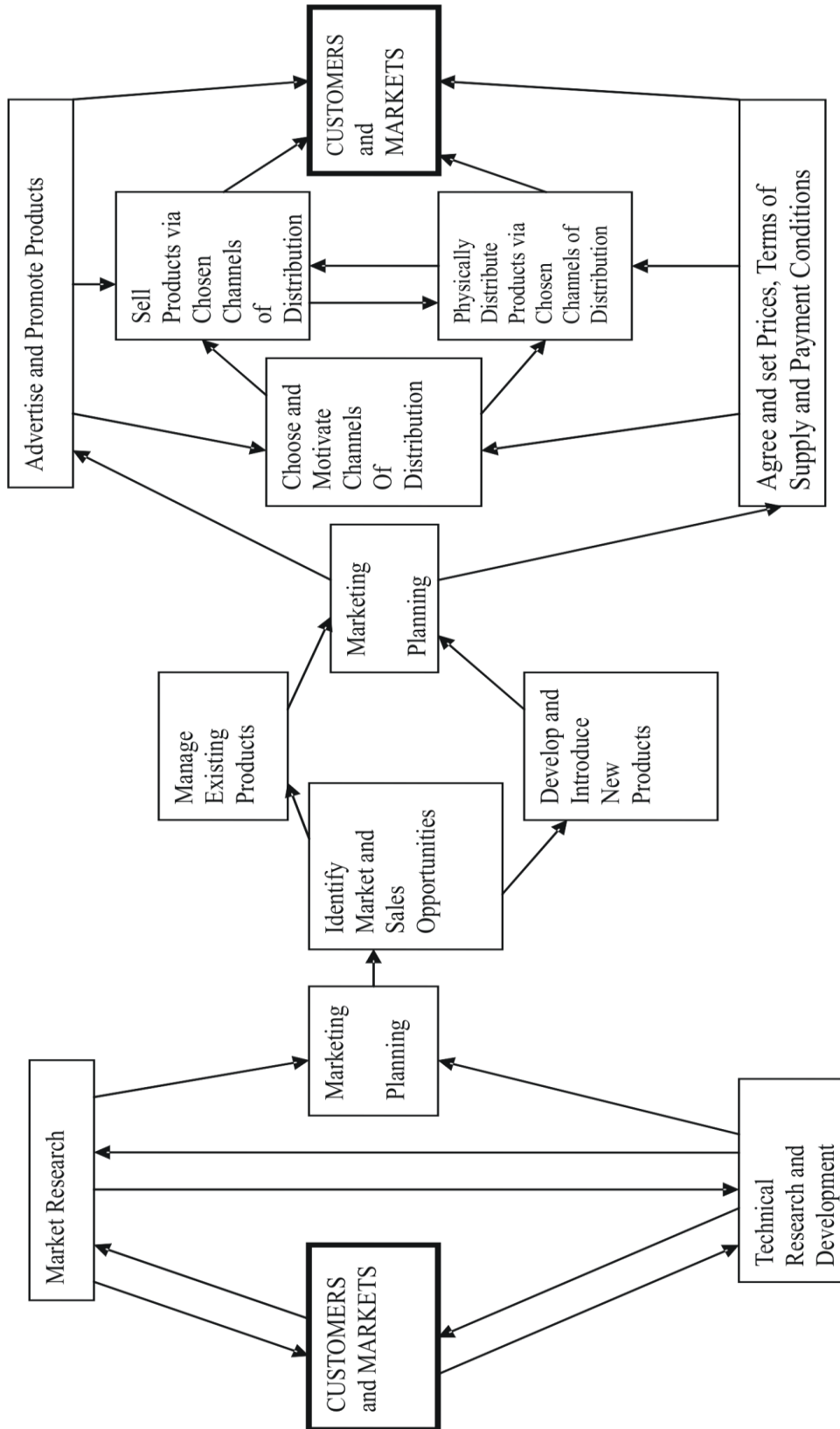

Figure 3.2 What does marketing actually do?¹⁴

Reference

- ¹ source: www.usaid.gov
- ² source: www.dogana-ks.org
- ³ Source: www.unmikonline.org
- ⁴ Source: www.akb-ka.org
- ⁵ source: www.odaekonomike.org
- ⁶ Kotler P., A Framework for Marketing Management, 2001
- ⁷ Taken from: RTK Marketing Unit, 2005
- ⁸ Taken from: RTK Marketing Unit, 2005
- ⁹ Taken from: RTK Marketing Unit, 2005
- ¹⁰ Neidle A., How to get into Advertising, 2001
- ¹¹ Adopted from: www.wikipedia.org
- ¹² Morden A.R., Elements of Marketing, 1993
- ¹³ Kotler P., A Framework for Marketing Management, 2001
- ¹⁴ Morden A.R., Elements of Marketing, 1993

4 SUMMARY AND FUTURE WORKS

Starting from the very beginning, it can be concluded that in Kosova there are companies which comprises a few elements of “Selling orientation” and “Product Orientation”, having in mind that they don’t have enough skills and other possibilities on investing elsewhere. The very good restaurants and fuel pumps were cited as examples of these market orientations.

So, the marketing concept is almost unknown by companies here. Though, some small consultancy companies have started to give their contribution in this area. This is a good job made by them, and they are going to facilitate all the market, enabling them to use new opportunities.

But, since there were no any surveys by marketers in Kosova done, then it was easy to conclude that market segmentation definitions, patterns of market segmentation and market segmentation procedures were used only by occasion and by intuit of marketers. On the other hand, a lot of products imported from abroad are dedicated based on Kosova market segmentation.

It was noticed that a lot of money are spent by marketers on advertising of their product or services. But, other promotional tools as sales promotion, public relations and direct marketing were left apart.

Based on the given explanation of marketing concept strategy and based on data collected about business environment on which Kosova’s companies operate, it can be concluded that these companies know just a little about possibilities that this new business concept offers. It was shown that the initial steps toward this orientation have begun. The further politico-economics stability and improvement is going to enables the companies to know, familiarize and to apply all of these potential possibilities that marketing techniques offer. Also, based on Kosova economic system progress trends, means Free-Market Economy, then the adequate business environment for marketing are going to be created, which in turn will facilitate entire development of economic system in Kosova.

4.1 FUTURE WORK

Having in mind that Marketing concepts and techniques are part of processes that change in parallel with changing economic environment, using them and dealing with them offers a lot of creativity. In the future I’ll try to find and adopt the best methods and techniques which would be considered as best appropriated for our business environment. As a new technique for our business environment, a lot of efforts should be done by marketers in Kosova on adopting this business concept. It remains to Marketing experts explaining in very meaningful way to the marketers the benefits of using this concept. Whenever I can, I’ll try to offer my best of my knowledge on implementing of Marketing concepts.

5 LITERATURE

1. Kotler P., Framework for Marketing Management, 2001
2. Rexha N., and Reshidi N., Marketing Bases, 2002
3. Morden A.R., Elements of Marketing, 1993
4. BILLES G.B., Marketing, 1994
5. Neidle A., How to get into Advertising, 2001
6. Salzman Andrew, Siebel Systems, 2001
7. Roddy Mullin, Direct Marketing, 2000
8. Ali M., Practical Marketing and PR for the Small Business, 1998
9. Perreault, McCarthy, Parkinson and Stewart, Basic Marketing, 1999
10. Blanchard B., and Fabrycky W., Systems Engineering and Analysis, 1997
11. Cannon T., Basic Marketing, 1996
12. Borden N., The Concept of the Marketing Mix, 1965
13. Bucklin, Theory of Distribution Channel Structure, 1966
14. Kotler P., Principles of Marketing, 1995
15. King S., Brand Building in the 1990's, 1991
16. Ali M., Practical Marketing and PR for the Small Business", 1991
17. Microsoft Encarta Encyclopedia Deluxe 2004
18. Microsoft Encarta World English Dictionary
19. Language Teacher 98 Eng - Alb

Web Links:

20. www.akb-ks.org
21. www.nationmaster.com/encyclopedia/Sales-orientation
22. www.tutor2u.net
23. www.peacemotivate.com
24. www.marketingteacher.com
25. www.businessbureau-uk.co.uk
26. www.netmba.com
27. www.quickmba.com
28. www.en.mimi.hu
29. www.indiainfoline.com
30. www.directmag.com
31. www.answers.com
32. www.bizhelp24.com
33. www.wikipedia.org
34. www.usoe.k12.ut.us
35. www.learnmarketing.net
36. www.tolearn.net

6 APPENDIX

Table 6-1 Sample of a survey questioner

ATTENTION! <input type="checkbox"/> <i>Multiple Choices!</i> <input checked="" type="radio"/> <i>Only one Choice!</i>
1. Do you take attention to the advertisements where ever they are (If the answer is NO, go to third question!)? <input type="radio"/> YES <input checked="" type="radio"/> NO <input type="radio"/> INFREQUENTLY
2. In which media do you follow the advertisements? <input checked="" type="checkbox"/> TV <input checked="" type="checkbox"/> RADIO <input checked="" type="checkbox"/> INTERNET <input checked="" type="checkbox"/> IN DIFFERENT POSTERS
3. How do you evaluate advertisements? <input type="radio"/> CLEAR ENOUGH <input type="radio"/> NOT CLEAR ENOUGH <input checked="" type="radio"/> COMPLETELY
4. Do you buy as a consequence of the promotion? <input type="radio"/> FREQUENTLY <input type="radio"/> RARELY <input checked="" type="radio"/> NEVER
7. Do you buy with Credit Card? <input type="radio"/> YES <input type="radio"/> NO